

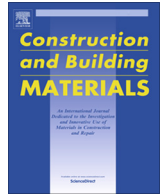

Contents lists available at ScienceDirect

# Construction and Building Materials

journal homepage: [www.elsevier.com/locate/conbuildmat](http://www.elsevier.com/locate/conbuildmat)

## Review

### Experimental characterization of the self-healing capacity of cement based materials and its effects on the material performance: A state of the art report by COST Action SARCOS WG2



Liberato Ferrara <sup>a,\*</sup>, Tim Van Mullem <sup>b</sup>, Maria Cruz Alonso <sup>c</sup>, Paola Antonaci <sup>d</sup>, Ruben Paul Borg <sup>e</sup>, Estefania Cuenca <sup>a</sup>, Anthony Jefferson <sup>f</sup>, Pui-Lam Ng <sup>g</sup>, Alva Peled <sup>h</sup>, Marta Roig-Flores <sup>i,1</sup>, Mercedes Sanchez <sup>c,2</sup>, Christof Schroefl <sup>j</sup>, Pedro Serna <sup>i</sup>, Didier Snoeck <sup>b</sup>, Jean Marc Tulliani <sup>k</sup>, Nele De Belie <sup>b</sup>

<sup>a</sup> Department of Civil and Environmental Engineering, Politecnico di Milano, Italy

<sup>b</sup> Magnel Laboratory for Concrete Research, Faculty of Engineering and Architecture, Ghent University, Ghent, Belgium

<sup>c</sup> Instituto de Ciencias de la Construcción Eduardo Torroja, Consejo Superior de Investigaciones Científicas, Madrid, Spain

<sup>d</sup> Department of Structural, Geotechnical and Building Engineering, Politecnico di Torino, Italy

<sup>e</sup> Faculty for the Built Environment, University of Malta, Malta

<sup>f</sup> School of Engineering, University of Cardiff, UK

<sup>g</sup> Faculty of Civil Engineering, Vilnius Gediminas Technical University, Vilnius, Lithuania

<sup>h</sup> Department of Structural Engineering, Ben Gurion University of the Negev, Beer Sheva, Israel

<sup>i</sup> Instituto de Ciencia y Tecnología del Hormigón, Universitat Politècnica de Valencia, Spain

<sup>j</sup> Institute of Construction Materials, Technische Universität Dresden, Dresden, Germany

<sup>k</sup> Department of Applied Science and Technology, Politecnico di Torino, Italy

## HIGHLIGHTS

- Review of test methods for assessing healing efficiency.
- Novel perspective in correlating healing to durability and mechanical recovery.
- Correlation between different test methods.
- Characterization methods of healing products.
- Pioneer monitored case studies are presented.

## ARTICLE INFO

### Article history:

Received 18 December 2017

Received in revised form 23 January 2018

Accepted 24 January 2018

Available online 9 February 2018

### Keywords:

Self-healing

Cementitious materials

Test-methods

Durability Properties

Mechanical properties

Self-healing products

Field evaluation

## ABSTRACT

Heuristically known at least since the first half of XIX century, the self-healing capacity of cement-based materials has been receiving keen attention from the civil engineering community worldwide in the last decade. As a matter of fact, stimulating and/or engineering the aforementioned functionality via tailored addition and technologies, in order to make it more reliable in an engineering perspective, has been regarded as a viable pathway to enhance the durability of reinforced concrete structures and contribute to increase their service life.

Research activities have provided enlightening contributions to understanding the mechanisms of crack self-sealing and healing and have led to the blooming of a number of self-healing stimulating and engineering technologies, whose effectiveness has been soundly proved in the laboratory and, in a few cases, also scaled up to field applications, with ongoing performance monitoring. Nonetheless, the large variety of methodologies employed to assess the effectiveness of the developed self-healing technologies makes it necessary to provide a unified, if not standardized, framework for the validation and comparative evaluation of the same self-healing technologies as above. This is also instrumental to pave the way towards a consistent incorporation of self-healing concepts into structural design and life cycles analysis codified approaches, which can only promote the diffusion of feasible and reliable self-healing technologies into the construction market.

\* Corresponding author.

E-mail address: [liberato.ferrara@polimi.it](mailto:liberato.ferrara@polimi.it) (L. Ferrara).

<sup>1</sup> Now at Instituto Eduardo Torroja de Ciencia de la Construcción, Centro Superior de Investigaciones Científicas, Madrid, Spain.

<sup>2</sup> Now at University of Cordoba, Spain.

<https://doi.org/10.1016/j.conbuildmat.2018.01.143>

0950-0618/© 2018 Elsevier Ltd. All rights reserved.

In this framework the Working Group 2 of the COST Action CA 15202 “Self-healing as preventive repair of concrete structures – SARCOS” has undertaken the ambitious task reported in this paper. As a matter of fact this state of the art provides a comprehensive and critical review of the experimental methods and techniques, which have been employed to characterize and quantify the self-sealing and/or self-healing capacity of cement-based materials, as well as the effectiveness of the different self-sealing and/or self-healing engineering techniques, together with the methods for the analysis of the chemical composition and intrinsic nature of the self-healing products. The review will also address the correlation, which can be established between crack closure and the recovery of physical/mechanical properties, as measured by means of the different reviewed tests.

© 2018 Elsevier Ltd. All rights reserved.

## Contents

1. Introduction	116
2. Techniques for pre-cracking/damaging and healing boundary conditions	117
3. Variables affecting the healing	120
3.1. Age of pre-cracking	120
3.2. Conditions of exposure and healing duration	120
3.3. Through-crack stress states	120
3.4. Repeatability	121
4. Methods for characterization of self-sealing/healing	121
4.1. Crack closure quantification	121
4.1.1. Surface cracks	121
4.1.2. Internal cracks	122
4.1.3. Preparation of samples, image analysis and crack sealing indices	123
4.1.4. Correlations between different crack width measurements	124
4.1.5. Healable crack width	124
4.2. Tests and methods based on the recovery of durability properties	124
4.2.1. Permeability	124
4.2.2. Sorptivity	125
4.2.3. Gas permeability	126
4.2.4. Chloride penetration	127
4.3. Tests and methods based on the recovery of mechanical properties	128
4.3.1. Tests and methods based on ultrasonic wave propagation	128
4.3.2. Mechanical tests	130
4.4. Methods of analysis of the healing products	132
5. Monitored case studies	137
6. Conclusions	137
Acknowledgements	138
References	138

## 1. Introduction

The susceptibility of concrete to cracking because of load- or deformation-induced stresses all along its service life is well known and represents one of the major hindrances to the durability of concrete structures. Cracks stand as a straightforward path for the ingress of harmful agents into concrete, whose bulk matrix, with modern high performance technologies, can be made as low porous as desirable.

Worldwide increasing consciousness for sustainable use of natural resources has made overcoming the apparent contradictory requirements of low cost and high performance a challenging task. *fib* Model Code 2010 has also recently highlighted the importance of sustainability as a requisite which has to inform structural design since from its concept. In this context, the availability of self-healing technologies, by controlling and repairing early-stage cracks in concrete structures where possible, could on the one hand prevent permeation of driving factors for deterioration, thus extending the structure service life, and on the other hand even provide partial recovery of engineering properties relevant for the application.

The ability of concrete and cement based materials, as well as of other hydraulic binders such as limes, to self-seal cracks has been “heuristically” observed for about two centuries, as exemplified by the research findings on autogenous healing by Loving [102] and Lauer and Slate [92].

The aforementioned capacity, depending on the age of cracking, crack width, as well as on a significant presence of water, was regarded as a sort of bonus: self-healing was able to counteract the drawbacks of early-age shrinkage cracking in certain types of structures, such as tanks and reservoirs, which, thanks to the presence of water, experience favourable conditions of exposure.

Though more systematic studies were carried out all along the second half of the last century (see, e.g., [66]), the topic has been gaining continuously increasing interest in this last decade. On the one hand this is due to the increased durability problems which have been observed in existing concrete structures, which require repair. The available repair solutions are expensive and can cause a lot of inconvenience when infrastructure has to be closed down. Therefore, there has been a growing interest in alternative, preventive measures. On the other hand, the interest in self-healing cement based construction materials is steered by

the sustainability commitment that the surging demand of buildings and infrastructures is requiring worldwide.

The COST Action CA15202 – Self-healing As preventive Repair of COncrete Structures (SARCOS), has gathered a community of European researchers active in this field, and, in view of the context described above, has merited the financial support of the European Commission, with the purpose of providing a synergy and multiplying effect of individual efforts. As a matter of fact, only such a synergy can effectively foster the market penetration of self-healing concepts and related technologies, also through an effective mastering of the developed technology and its transfer into suitable product norms, test standards and design guidelines.

Flourishing research and development activity in the last years has led to the concept and validation of countless techniques to promote and enhance the self-healing capacity of cement based materials. Because of this, the scientific community has first of all collaborated in order to define a common terminology framework (RILEM TC 221-SHC, [30]). The concepts and mechanisms of autogenous and autonomous (engineered) healing as well as the difference between self-sealing and self-healing of cracks, the latter implying the recovery of the material properties as a consequence of crack sealing, are nowadays definitions internationally agreed upon [105,113]. This has also made it possible to provide a unifying framework to consistently categorise the aforementioned self-healing technologies, as a function of human interference to stimulate autogenous self-healing (through mineral additions, crystalline admixtures, superabsorbent or other polymers), or to provoke autonomous self-healing, by introducing, e.g., encapsulated polymers or minerals, or bacteria [26]. In a design-wise and application-oriented perspective, it is required to evaluate the effectiveness of the different proposed self-healing technologies with reference to one or more material properties, depending on the intended application. This also with reference to the possibility of consistently comparing, in a performance based framework, two or more different self-healing technologies in order to select the most appropriate one for the intended application [117].

This assessment has to take into account a set of multi-fold experimental variables, which include:

- the initial opening of the crack and the age of cracking;
- the curing conditions during the healing period and its duration;
- the presence of sustained loading along the healing period, which results into through-crack stress states;
- the repeatability of the healing action and its effectiveness in consequence of successive repeated cracking phenomena, at the same and/or at different locations.

This paper, prepared in the framework of the SARCOS WG2 activities, aims at providing a comprehensive and critical review of the experimental methodologies, which have been employed to characterize and quantify the self-sealing and/or self-healing capacity of cement-based materials. It will also address the correlation, which can be established between crack closure and the recovery of physical/mechanical properties, as measured by means of the different reviewed tests.

This effort is intended to pave the way towards standardization of such testing methods for assessing the effectiveness of different technologies, aiming at incorporating self-healing concepts into durability-based predictive models and design approaches.

## 2. Techniques for pre-cracking/damaging and healing boundary conditions

In order to evaluate the effectiveness of a self-healing technology, be it either autogenous or autonomous, a preliminary level

of damage (pre-cracking) has first to be induced on the specimen. This damage is preferably induced in a controlled way in the form of either a localized crack or a multiple cracking pattern. The self-healing effectiveness can then be evaluated by measuring the closure or sealing of the crack, and/or the recovery of mechanical properties with respect to the undamaged state. The recovery in mechanical properties over time has to be evaluated through the same test employed for pre-cracking, or alternatively through the comparison of suitable test measurements garnered immediately after pre-cracking and again after a scheduled healing period. Comparison with the performance of companion undamaged specimens undergoing the same curing history as the healing ones is also of the utmost importance in order to discriminate between healing and natural time-gain and aging of concrete mechanical properties.

Most commonly, cracks are induced in by the application of loads. However, it is noted that they can also be induced by restrained deformations, such as restrained drying shrinkage, or other physical causes, such as freeze and thaw cycles. In the case of self-healing investigation, cracks have been most commonly induced in a mechanical way. This is primarily due to the need of controlling the opening of the single crack, which plays a role of paramount significance also in the assessment of self-healing efficiency. Several tests have been employed for mechanical pre-cracking, which can be sorted into one of the following categories:

- three- or four-point bending tests, on either un-notched or notched specimens;
- direct tensile tests;
- tensile splitting tests, or other indirect tensile tests;
- compression tests.

The type of test employed for pre-cracking has to take into account the behaviour of the material whose self-healing capacity has to be investigated. Plain concrete is inherently brittle, and closed-loop crack opening controlled tests are needed in order to induce a crack under bending, splitting or direct tension (in order of difficulty). Pre-damaging specimens by means of compression tests has also been reported [101], mainly in the case of brittle weak materials, such as lime mortars [27,28].

In the case of Fibre Reinforced Concrete (FRC), which has a tougher behaviour than plain concrete, even a displacement-controlled test may provide a stable post-cracking response and hence a suitable control of the cracking phenomenon. This has led some authors to employ a limited amount of fibres just in order to make the post-cracking behaviour more reliable. Alternatively, this can also be achieved by using internal reinforcement (wires or bars, depending on the dimensions) or external strengthening (e.g. Carbon Fibre Reinforced Polymers).

High Performance Fibre Reinforced Cementitious Composites (HPFRCCs) and Textile Reinforced Concrete (TRC) feature a one of a kind tensile behaviour characterized by a stable multiple cracking and tensile strain hardening response. This allows the use of direct tensile tests to evaluate the effects of crack sealing on the recovery of the aforementioned signature performance under tensile loads. The stable behaviour of the material also in the cracked state does not require a closed-loop feedback controlled test. Nonetheless, the multiple cracking behaviour highlighted above, makes test-garnered parameters, such as the deformation of the specimen measured by means of a LVDT across a gauge length, only indicative of a certain level of overall damage but not at all representative of the opening of each single crack. This has to be quantified thereafter by means of, e.g., image analysis of crack micrographs, unless a notch is introduced which forces the opening of one single crack.

For the determination of the crack sealing and its effects on durability properties (such as water absorption, water permeability, resistance to chloride penetration,...) the type of pre-cracking test which is used does not play a significant role, since its only function is to introduce a crack. The choice of pre-cracking test is also determined by the specimen shape, the desired crack shape and the type of material which has to be tested.

The first criterion of choice is related to the type of test which is used to evaluate the recovery in the durability parameters, the type of test to be employed for the durability recovery measurement governing the choice of the test to be employed for pre-cracking.

A second criterion concerns the geometry of the crack, also with reference to the “real” structural situation they intend to replicate. As a matter of fact, it is clear that a crack generated by means of three- or four-point bending have a width varying along its depth, the crack being the widest at its mouth and decreasing its width towards the tip. These bending cracks are typically found in beams and plate elements. Direct tensile and tensile splitting tests result in cracks with a more uniform width lengthwise. These types of cracks may be less frequently encountered in real practice, but may for example reproduce the case of restrained deformation cracking experienced by precast elements in transient situations, as well as cracks in 2D elements experiencing biaxial membrane stress states.

The last criterion is related to the material behaviour, as already explained above. Three- or four-point bending tests have been used to pre-crack plain concrete or ordinary FRC specimens in order to evaluate the crack sealing via water flow or absorption tests. Refs. [106,216,83,84,9,172,63,64,184] or (tensile) splitting tests [8,181,158,83,140,141,124] In the case of HPFRCC, as well as in the case of Textile Reinforced Concrete (TRC) specimens, for which it may be of interest to investigate the effects of self-healing on the recovery and long-term persistency of the tensile behaviour, direct tension tests have been frequently employed [68,96,205,98,110,121,122,35]. Splitting tensile tests have been also used to pre-crack specimens which are used for the investigation of the effects of self-healing on the resistance to chloride penetration, because of compliance with the standards related to durability properties [125,126,147,148,216,153,213]. Moreover, splitting tensile tests have been used to pre-crack TRC to assess fluid transport properties [36].

On the other hand, for the determination of self-healing and its effects on the recovery of mechanical properties, the test used for pre-cracking the specimen needs to be the same one as used to assess the self-healing capacity of the specimen after a certain healing period. Therefore, the employed test will depend on the material property of interest whose self-healing induced recovery has to be evaluated. For example, in order to determine the recov-

ery of flexural strength or stiffness, three-point bending [9,188,43,45,83,98,137,181,189,191–193], and four-point-bending tests [46–49,87,97,106,125,126,135,136,153,156,157,159–162,158,160,184,204,209,213] have been employed.

Three-point bending tests, because of the determinedness of the crack position, often also forced through the introduction of a notch, have been employed for plain concrete and ordinary FRC. It is worth here remarking that in the case of plain concrete a closed loop deformation (crack-opening) controlled test is often needed to obtain a stable post-cracking response and hence provide an effective control of the induced crack-opening. Four-point bending tests, where cracks may form at any location in the central constant bending moment region of the specimens, have been preferred in the case of HPFRCCs, also to allow multiple cracking in the same zone. In this case the stable deflection hardening behaviour allows for the use of a simple machine head displacement control. It is once again worth remarking that the formation of multiple cracks and the indeterminacy of the crack positions do not allow in this case a LVDT measured crack-opening parameter to be easily obtained from the test. Generally, a prescribed level of damage is assessed through a deflection level and/or the cumulative crack opening measured astride a given gauge length encompassing the constant bending moment region. The opening of each single crack has to be later assessed by means of image analysis of crack pattern micrographs.

The use of compression strength tests has also been reported [1,101,128] in studies on the recovery of compression strength after severe loading or when this property was of interest for the intended “in-structure” material performance [27,28].

Specifically, in the case of fibre reinforced cementitious composites the effects of self-healing on the recovery of the fibre–matrix bond has been also explored. This has resulted into one of a kind “pre-damaging” techniques, where a “pre-slip” between the fibre and the matrix was introduced [49,88,98]. Also, in the case of TRC, the recovery over time of the fabric–matrix bond was explored, as promoted through the use of mineral additives [22,35].

Table 1 gives an overview of the different pre-cracking methods and their applicability for different classes of cementitious composites.

When mechanical loading is applied to pre-crack specimens it is important to highlight the effects of elastic regain on crack opening upon load removal. Even for identical specimens which have been loaded in a crack-width controlled test set-up up to the same crack width, there can be quite some variation of the residual crack width [63,64], as it has been also confirmed in a recent round robin test with reference to specimens pre-cracked in three-point bending [172]. This variation is also affected by the technique used for

**Table 1**  
Overview of suitability of pre-cracking methods for different classes of cementitious composites. “Common” indicates that the test has been frequently reported in literature. “Possible” indicates that the test is possible but insufficiently documented.

Type of test	Plain concrete	FRC	TRC	HPFRCC
Compression	Common	Possible	Possible	Possible
Direct tensile	Difficult, hardly ever employed	Possible but not commonly employed.	Common due to strong tensile strain hardening behaviour. Multiple cracks will form.	Common due to strong tensile strain hardening behaviour. Multiple cracks will form.
Tensile splitting	Common, if the crack width needs to be controlled special measures have to be taken.	Common	Possible	Possible
Three- or four point bending	Common but may require closed loop control or the use of internal/external reinforcement for stable cracking.	Common	Four-point bending is most common. Allows formation of multiple cracks in the central part of the specimen.	Four-point bending is most common. Allows formation of multiple cracks in the central part of the specimen.
Pre-slip between fibre and matrix	N/A	Common	Common	Possible

monitoring the crack width during pre-cracking, as well as by the technique used for the measurement of the residual crack width after unloading.

The variation of the residual crack width affects the accuracy and robustness of the measurement of the self-healing capacity

[63,64,172,218], highlighting the need for a stable cracking method resulting in a low variation of the residual crack width. However, it should be noted that the residual crack width is not an ideal parameter to describe a crack. The crack width is measured on the surface of a specimen but this hardly provides any information about the interior of a crack. Two specimens can have the same residual crack width on their outside surface but can have a completely different crack geometry in their bulk.

The 3D layout of a crack is a function of the mix composition of the investigated material. For example, in mortar specimens, cracks may generally be more uniform than in concrete when looking at the meso-scale, because of the lack of coarse aggregates, which allows a more uniform structure of the crack. The meso-structure of concrete, on its hand, is less homogenous and is governed by the presence of the coarse aggregates. Compared to normal plain concrete, HPCFRCCs and TRC, which also do not employ coarse aggregates in their mix design and employ even very fine sands (often sieved to below 1 mm maximum grain size), do feature a highly uniform structure of the cracks, besides the much more stable cracking behaviour already recalled above [202,215].

The need to visualize the interior of a crack has recently been addressed by the use of X-ray computed tomography, which allows a complete 3D visualization of the interior of a specimen, as well as the formed healing products [184,161,162], as is illustrated by Figs. 1 and 2, even if no quantitative parameter (e.g. crack volume) has been so far garnered from the aforementioned observations. Such a quantification would be of the utmost importance for a reliable evaluation of the healing efficiency, since a crack with a narrower width at its mouth and also with a lower throughout volume will be easier and faster healing and may even experience a more effective reconstruction of the through-crack physical and mechanical material continuity.

As an alternative to pre-cracking specimens via mechanical loading some researchers have used other methods to produce a pre-cracking: a non-through going cut [1]; pre-inserted metal

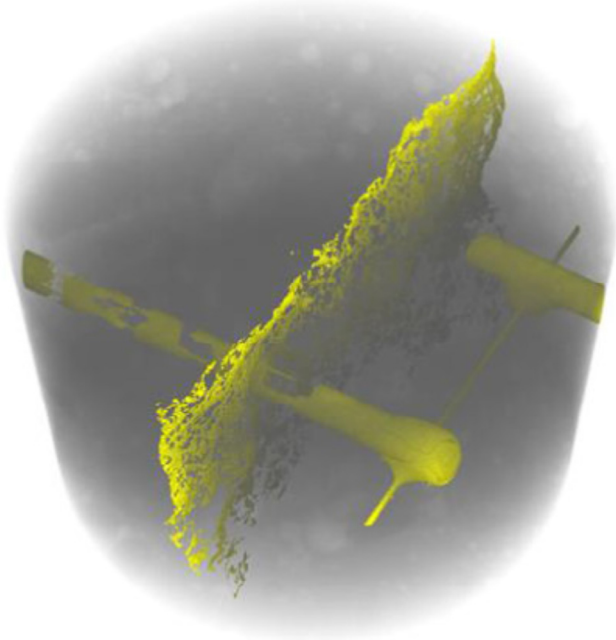

**Fig. 1.** Three-dimensional visualization of the interior of a crack of a specimen with encapsulated polymers: the yellow represents the polymer that filled the crack or remained in the capsules [184]. (For interpretation of the references to colour in this figure legend, the reader is referred to the web version of this article.)

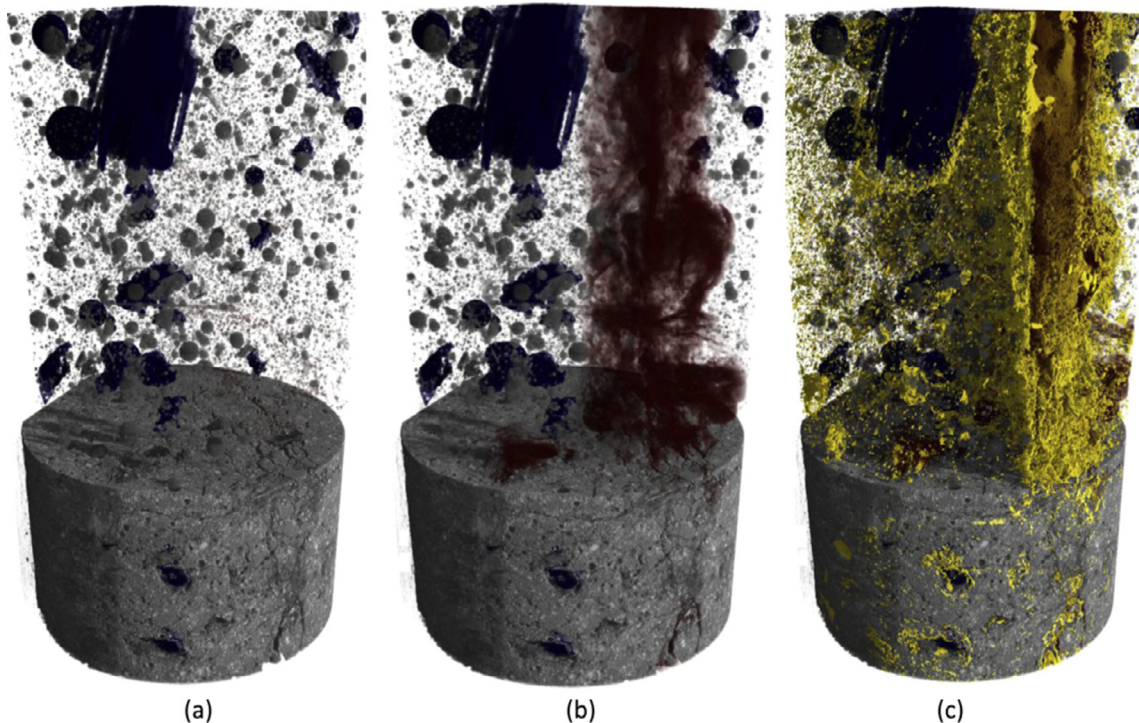

**Fig. 2.** Three-dimensional images of specimen with superabsorbent polymers with the porosity in grey and blue (a), the crack in red (b) and the formed healing products in yellow (c) [162]. (For interpretation of the references to colour in this figure legend, the reader is referred to the web version of this article.)

plates to be pulled out several hours after the concrete has been cast thus creating a non-through going crack [175], or sawing the specimens in halves and positioning them back, in case controlling the surface crack width through an optical microscope [129,5].

### 3. Variables affecting the healing

When comparing different studies dealing with the self-healing behaviour of cementitious materials, not only the applied test methods are of importance but also different initial and boundary conditions which can significantly affect the obtained results.

Firstly, depending on the time of pre-cracking, un-hydrated particles of cement and/or supplementary cementitious materials will still be present. This affects the degree of autogenous healing with respect to the total healing. Secondly, the efficiency of the healing mechanisms can be greatly influenced by the exposure conditions, e.g. the presence of water, especially with reference to autogenous healing. Thirdly, the healing behaviour can be influenced by a stress state normal to the crack surfaces; a compressive stress results in a mechanical crack closure, while a tensile stress results in a mechanical crack opening. Lastly, the formed healing products can be damaged and the healing process can be disrupted if the crack is unstable. Furthermore, the width of the crack itself is of importance, since, as it will be explained further, the efficiency of the healing clearly depends, also as a function of the self-healing mechanism, on the initial width of crack which has to be closed, wider cracks needing a longer time or a more effective stimulating/engineering mechanism to be effectively healed.

#### 3.1. Age of pre-cracking

The age of pre-cracking plays an important role in studying healing phenomena. Autogenous healing can be attributed to: the precipitation of calcium hydroxide and calcium carbonate, mechanical blocking and obstruction of tight crack volumes by small particles, swelling, and rehydration of the cement paste near the crack [8,26]. The rehydration of the cement paste causes a delayed hydration of cement grains which have not yet reacted due to a lack of water. Such un-hydrated grains are particularly abundant in case a low water-to-cement ratio is used in the mix design. This is the dominating mechanism for young concrete, since there is still a significant amount of un-hydrated cement particles [120,182]. The precipitation of calcium hydroxide and calcium carbonate is the result of a carbonation reaction between carbon dioxide, which is present in water or air, and the calcium ions of the concrete [218]. Carbonation is the dominating mechanism for autogenous healing at later ages [120]. It is anyway worth remarking that it is related to the interaction of the crack with the surrounding environment as well as to the moisture state, which can vary along the same crack.

For concrete containing latent hydraulic (e.g. blast furnace slag) or pozzolanic (e.g. fly ash) binder materials, which have slower hydration than cement, there can still be delayed hydration at later ages, thus guaranteeing a larger time span in which unreacted binder material is available [184,180,181,46,214].

It is important to highlight that the age of pre-cracking is not necessarily related to a certain type of healing mechanism but can also be related to a certain type of damage, as anticipated to occur all along the design service life of the structure. Early age cracks in concrete can form due to restrained shrinkage and/or thermal deformations [206,207,149]. Formia et al. [51] for example used the ring test in order to create restrained shrinkage cracking and check the related healing capacity. Cracks induced at a later age represent a load- or deformation-induced cracking when the structure is under service conditions. In a standard situation,

design codes assume 28 days as a reference age, where most of the hydration can be deemed as concluded for conventional concretes. Pre-cracking at later ages (older than 28 days) has been also reported and can be intended to check the viability of healing agents after a dormant period, such, e.g., the effectiveness of bacteria, crystalline admixtures, encapsulated polymers etc. This can also be the case when supplementary cementitious materials with pozzolanic action (fly ashes, slag) are used, whose activity, and hence contribution to autogenous healing, may take longer time to be consumed.

#### 3.2. Conditions of exposure and healing duration

Once concrete specimens have been pre-cracked, they have to be exposed to prescribed conditions, after which the amount of healing will be tested. These exposure conditions are chosen either for their good compatibility in combination with the used healing product or as representative of the intended/anticipated field of application. Several exposure conditions have already been investigated [206,207,147,43,48,123,161,162], including, e.g., exposure to the local climate or to air in a climate room with a controlled temperature and relative humidity, submersion in water (at different temperatures), contact with water in the cracked region of the specimen, wet/dry cycles, freeze/thaw cycles and winter/summer cycles. The employed water is usually distilled water or tap water but can also contain aggressive substances. An example can be a diluted chloride solution to simulate sea water [72,98,107,127] or ponding which may occur in structural elements where de-icing salts are used [15,25]. Instead of aggressive substances, it is also possible that the water contains a beneficial agent, e.g. a food source to promote bacterial activity [1,101]. For most healing techniques the presence of liquid water [44,140,192,104] or a humid environment [158] is required in order to produce a significant amount of healing. The only exception to this rule appears to be in the case of encapsulated liquid polymers, like e.g. polyurethane and methyl methacrylate, which are able to induce self-healing when they harden upon contact with air, the moisture in the concrete matrix or another polymer component [182,184].

In the surveyed literature there is a wide variation in the reported healing duration, which is strongly dependent on the applied healing technique. Capsules filled with cyanoacrylate can heal a crack within less than a minute [182], while autogenous healing can still continue even after two years [46–49] even if, as his last part, as noted by In et al. [72] for specimens ponded in a simulated sea water solution and also confirmed by Maes et al. [108], most of the autogenous healing was accomplished after 35–50 days.

#### 3.3. Through-crack stress states

Most of the tests reported in the literature have analysed the healing performance in specimens not subjected to any kind of load. However, structural elements in real-life service conditions experience sustained loads which generate through-crack stress states.

A compressive stress it will have a beneficial effect on the healing since the stress will close the crack partly. This situation could, for example, happen in precast columns or tunnel segments, which could crack during transportation. Once operating in the final structural configuration, they will be subjected to axial or circumferential compressive stresses. This latter case has been assumed as a reference by Ferrara et al. [44,45], who investigated the effects of through crack compressive stress on the healing capacity of different FRC mixes, either autogenous or stimulated via crystalline admixture and latex polymer, employing notched beam specimens previously pre-cracked in three-point bending.

On the other hand a tensile stress will have an adverse effect on the healing. Ozbay et al. [125], who studied sustained flexural loading in Engineered Cementitious Composites (ECCs), attributes this to the fact that the tensile sustained stress widens the pre-crack. Anyway, Yildirim et al. [210], testing specimens undergoing sustained flexural load observed only a slight decrease in strength recovery, as compared to unloaded specimens.

### 3.4. Repeatability

The healing process can be disrupted if the crack is unstable. This happens e.g. under cyclic loading of structural bridge elements or thermal day/night loading of restrained elements: cracks open and close continuously. This makes repeatability of crack healing a desirable trait for practical use of self-healing concrete, or alternatively the use of a very elastic healing material that bonds well to the crack walls and keeps the crack sealed. In the literature there have already been several studies about effectiveness under repeated cracking/healing cycles of different healing techniques, including, e.g., slag replacement [128], encapsulated polymers [41,42], super-absorbent polymers (SAPs) [159,160], and crystalline admixtures [24,25]. It has been observed that in the case of autogenous healing, the repeatability can pose a problem since the required materials for healing are consumed over time, mainly in the case of larger cracks (>0.15–0.2 mm) and under exposure conditions without continuous availability of water. With reference to SAPs, the promoted autogenous healing sometimes resulted in a perfectly healed matrix. This led to the formation of new cracks elsewhere, where the “reservoirs” for healing were not consumed yet [159,160]. Anyway, as a general remark, it can be stated that the previously created but autogenously healed cracks tend to reopen upon reloading. Other stimulated healing techniques, such as the use of crystalline admixtures, were also demonstrated to be effective in promoting continuous healing, up to one-year cracking-healing cycles under continuous water immersion, with 1/2 month frequency [25] – Fig. 3.

## 4. Methods for characterization of self-sealing/healing

After pre-cracking and at the end of the scheduled healing duration under the intended exposure conditions, the quantification of the healing is performed. This is a multi-fold task which generally encompasses the quantification of the crack closure, the recovery of one or more engineering properties of interest, as well as a quantitative assessment of their mutual correlation. The characterization of healing products often complements the aforementioned investigation and, helping to understand the nature of the healing

mechanisms and of the related property recovery phenomena, is also instrumental in view of model formulation.

### 4.1. Crack closure quantification

Closure of a crack is the most direct manifestation of self-healing, and thus it is the first necessary step for the evaluation and assessment of self-healing. The most common techniques employed to quantify crack closure are described hereafter.

#### 4.1.1. Surface cracks

The evolution of surface cracks is the most straightforward method to evaluate self-healing, and because of this it has been frequently used as an additional method to support other tests. Methods for its evaluation range from the naked eye to microscopy techniques, including:

- *Photography cameras*: generally employing high resolution charge coupled device (CCD) [85,130] or digital single-lens reflex (DSLR) [118], programmed to take pictures periodically to register the appearance of cracks in specimens during testing and after healing. The photogrammetry could be combined with various advanced Digital Image Correlation (DIC) techniques, including the Electronic Speckle Pattern Interferometry (ESPI) [21], which, though not yet applied to specific concrete self-healing investigations, may have good potential.
- *Light microscopy (optical, digital and stereo)*: using visible light as the radiation source [170,68,3,76,154,155,157,181,47,140,9,54]. This is the most common method. Some microscopes have specific functions to get additional information on self-healing, namely about the composition of the healing products, such as polarized microscopy in thin sections [119,155,23,184] or fluorescence microscopy, which uses fluorescence in addition to reflection of visible light [184].
- *Electron microscopy*: using electron beams. Main types are Transmission Electron Microscope (TEM) and Scanning Electron Microscope/Energy Dispersive Spectroscopy (SEM-EDS). The latter has been used to analyse precipitates inside a healed crack and their composition rather than for evaluating the evolution of the crack size [75,68,3,80,69,43,54].

It is worth remarking that only surface photographing and light microscopy in the reflectory mode can be applied to a specimen without the need to destroy it for sample preparation. Therefore, these two methods are the most suitable for repeated observations all along the healing period.

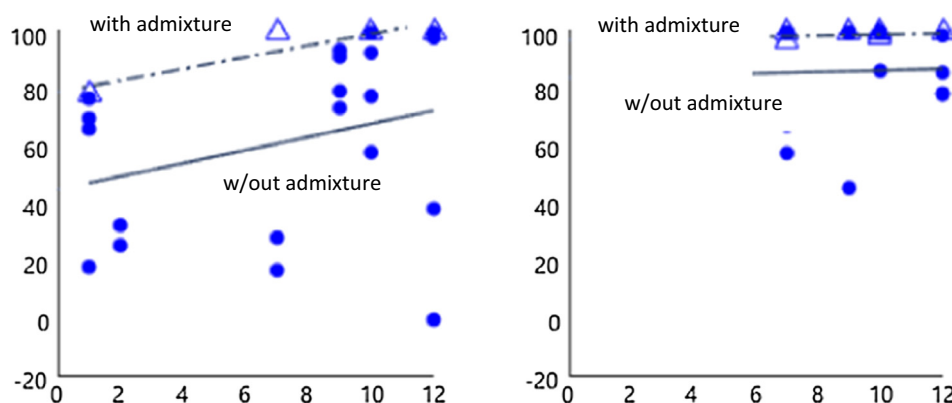

**Fig. 3.** Repeatability of crack sealing: Index of crack sealing vs. healing time for concrete without (M1) and with crystalline admixtures (M2) upon repeated cracking and healing under water and for different duration of the first healing (1 month, left – 6 months, right) [25].

#### 4.1.2. Internal cracks

Several studies showed that in some cases healing is able to close surface cracks [155] but the effectiveness of a healing strategy has to be assessed also with reference to its ability to close the cracks internally. To this purpose fibre optic sensing and tomography techniques have been proposed, due to their use of penetrating waves, such as:

- *Fibre optic sensing*: The potential use of fibre optic sensing in monitoring the healing of cracks in concrete has been postulated by Mihashi et al. [112]. For the general purpose of evaluation of internal cracks, fibre optic distributed sensing [186,139] could be considered. It has the advantages of: (a) continuous spatial measurement of crack widths by installing the distributed sensing system along the specimen dimension, therefore predetermination of exact crack locations is not required, (b) perpetual monitoring of the time-variation of crack widths by which the time of initiation and rate of self-healing can be revealed, (c) non-destructive evaluation of internal cracks, and (d) minimal health and safety hazard with the absence of radiation risk.
- *X-ray radiography or tomography*: X-rays applied to an object are partially absorbed, depending on its density and composition, by exciting its electrons. This allows the differentiation between aggregate, matrix and voids (either pores or cracks) [174,179].
- *Neutron radiography or tomography*: neutron rays interact with atomic nuclei, showing different patterns from X-rays. So far, Neutron Tomography has been used so far to visualize water uptake by a crack due to the high hydrogen detection sensitivity [183,176].
- *Computerized Tomography scan (CT-scan)* is a combination of X-ray images taken from different angles to create cross-sectional 2D images or 3D compositions. Micro-Computerized Tomography ( $\mu$ CT) is a type of CT for small scale objects with increased resolution and it has been successfully used to discern voids

[138] and internal cracks in concrete [179,184,161,162]. Similar processing has been also done on neutron tomography images, in order to visualize healing products [183,192].

- *Electrical methods*: a non-destructive evaluation of cracks and damage within a concrete specimen can be also performed by measuring its electrical properties (under Direct Current DC and Alternate Current), when highly conductive fibres such as steel or carbon are added into the concrete [198,109,173,33,168]. Using the frequency-dependent electrical properties of the fibre reinforced cementitious composite, measurement of the impedance values during the fracture process can be used to detect crack propagation. As a matter of fact, the electrical properties of the fibre reinforced concrete under DC or low frequency AC are dependent almost entirely on the concrete matrix, while the resistance at high frequencies is dependent almost solely on the fibre properties and geometry. The correlation between crack growth and the electrical impedance values at specific load–displacement points was studied prior and during tensile loading, while recording the crack development by digital camera for subsequent DIC analysis [131,171]. The use of continuous carbon fibres as a strain sensory device was also studied [197,199]. Recently it was reported the use of textile that contains carbon bundles as sensors rather than single bundle of fibres, i.e. TRC elements in which the textile serves as crack sensor as well as concrete reinforcement [58,59,57]. Though employed so far for crack healing evaluation only in a pioneer study by Yildirim et al. [212], such methods using conductive fibres either in the form of short, continuous or textile reinforcement, can also be effectively employed to the aforementioned purpose.

Table 2 summarizes the advantages and disadvantages of each method to evaluate self-healing by means of crack closure. The most complete information comes from tomography techniques. However, the expensive equipment may not be readily available,

**Table 2**  
Advantages and disadvantages of methods to evaluate crack closing.

Method	Advantages	Disadvantages
Photography cameras	<ul style="list-style-type: none"> <li>– Largest area of visualization</li> <li>– Allow acquisition of data during testing.</li> <li>– Easy continuous monitoring for fast self-healing methods.</li> </ul>	<ul style="list-style-type: none"> <li>– Generally, needs certain distance to cover the whole specimen</li> <li>– Less detail for a specific crack.</li> </ul>
Light microscopy (optical, digital and stereo)	<ul style="list-style-type: none"> <li>– Cheap and easy to implement. Easy preparation of samples.</li> <li>– Visualization of the surface crack as seen by the eye but at improved resolution, while showing natural colors.</li> <li>– Larger area visualization</li> <li>– Good results for 0.05–0.30 mm cracks</li> </ul>	<ul style="list-style-type: none"> <li>– Not able to evaluate internal crack width, unless through thin sections taken in “tailored” mode</li> <li>– Not able to evaluate composition of precipitates</li> </ul>
Polarized and fluorescence functions for light microscopy	<ul style="list-style-type: none"> <li>– High contrast in the borders between matrix and voids or cracks</li> <li>– Allows identification of crystalline solids from optical properties</li> </ul>	<ul style="list-style-type: none"> <li>– Needs time-consuming preparation of samples with polarized epoxy or fluorescence filter sets</li> </ul>
Electron microscopy	<ul style="list-style-type: none"> <li>– Allows complementary tests of the composition of precipitates, e.g. by EDX.</li> <li>– Generally, focus on small size cracks.</li> <li>– Good for verifying autogenous healing.</li> </ul>	<ul style="list-style-type: none"> <li>– Expensive compared with light microscopy techniques.</li> <li>– Only in grey scale depending on the atomic number of the element.</li> </ul>
Fibre optic sensing	<ul style="list-style-type: none"> <li>– Predetermination of crack locations is not required.</li> <li>– Reveals time-variation of crack widths.</li> <li>– Non-destructive and absence of radiation risks.</li> </ul>	<ul style="list-style-type: none"> <li>– Delicate specimen preparation works with embedded sensors.</li> <li>– Risk of damaging the sensors</li> </ul>
Tomographies and CT-scans (X-rays and neutron)	<ul style="list-style-type: none"> <li>– Internal crack evaluation, in the damage and healing stage.</li> <li>– Allows the differentiation by densities of the materials</li> <li>– In the case of neutron tomography, high sensitivity for hydrogen detection, good for analysis of water uptake</li> </ul>	<ul style="list-style-type: none"> <li>– Extremely expensive and low availability of equipment</li> <li>– Health and safety hazard due to radiation risks</li> <li>– Time consuming</li> <li>– High resolution only for small samples</li> </ul>
Electrical methods	<ul style="list-style-type: none"> <li>– Reveals time-variation of crack width</li> <li>– Can be applied to specimens and structural elements under load</li> <li>– Non-destructive</li> </ul>	<ul style="list-style-type: none"> <li>– May require dedicated and expensive equipment and suitable post-processing model to correlate electrical measure with crack width</li> </ul>

the health and safety hazards due to radiation risks must be appropriately eliminated, image capturing and processing are time consuming tasks, and a high resolution can only be obtained for very small samples.

#### 4.1.3. Preparation of samples, image analysis and crack sealing indices

Before taking images of the cracks, a specific pre-treatment may be needed, even when using the most basic light microscopes. One possible pre-treatment is the use of compressed air to clean the cracks and remove particles and/or detached grains of precipitates before taking photos [140,141]. Other authors have reported polishing and impregnating samples with dye epoxy under vacuum before using a stereo microscope, or polarized epoxy when using polarized light [155]. Another pre-conditioning action applies to concrete samples that heal when submerged in water, and consists of drying the samples for a few hours in a lab environment before taking the images [141], since the presence of water in the crack will produce odd brightness when illuminated with the microscope lights. These procedures can have great importance in improving the reliability and comparability of crack closing measures. It is noted that a pre-treatment can also often be omitted in the case of reflective microscopy. For some pre-treatment methods, such as cutting in smaller pieces or polishing, special care should be taken since they can produce new cracks or alterations in existing cracks of the sample that reduces the reliability of the crack closure evaluation.

To analyse self-healing through crack closure, it is necessary to compare the initial crack width with its value after the healing pro-

cess. To this purpose, the points where the evolution of the crack width is assessed need to be decided before healing takes place in order to reduce subjectivity. Since self-healing can be a random phenomenon, the greater the length of a crack that is analysed, the higher the representativeness of the analysis will be.

The analysis of crack widths requires the use of a size reference and standard photography software or specific measuring software from microscopes. The parameters that can be analysed are:

Crack width measured at specific points [76,157,181], or as the average width along a pre-determined length [47,141] (Fig. 4a-b). It can be estimated as the average of values measured at several points on the same specimen [140,141] or by the area under the plot of initial vs final crack width [76,155,181] (Fig. 5).

Crack area or volume This technique requires the picture of the crack path to be digitalized and suitably filtered so that the crack area can be evaluated by counting the number of black pixels [47,140], calculating the crack area in a specific section [83] or estimating the total area [140] (Fig. 4c).

Similarly to the method of black pixels, in the case of tomography, direct visualization of the volumes in a specific colour [183] shows the volumes of voids and cracks (Figs. 1 and 2). After post-processing the results, selecting areas with different brightness values allows the selection and measurement of areas of different densities, and then, the estimation of the volumes of pores and cracks [68,138,161,162].

The problem of the last method, when using black areas, is that cracks will need to be isolated from pores for a clear evaluation of crack healing.

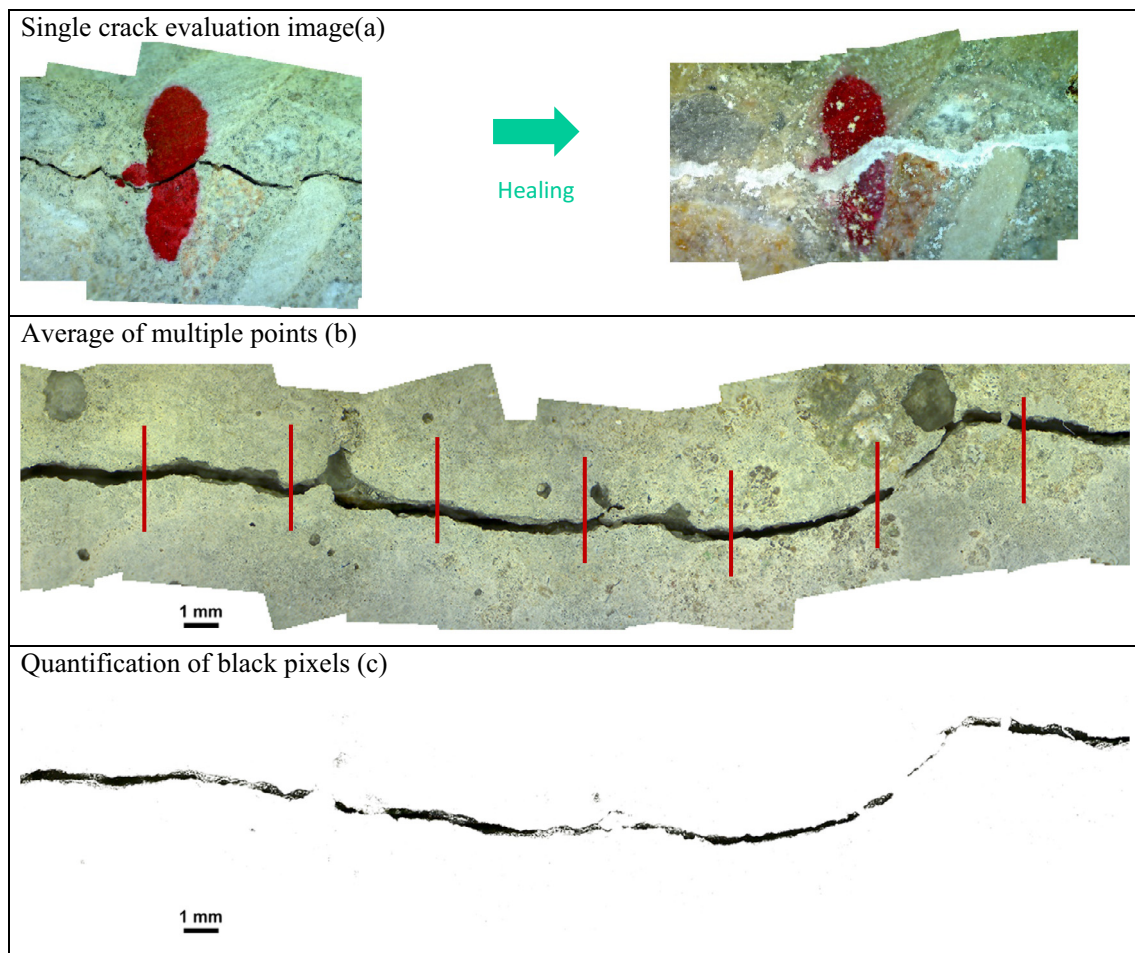

Fig. 4. Evaluation methods through evaluation of single cracks (a), average values of multiple points per specimen (b) and black pixels evaluation (c) [140,141].

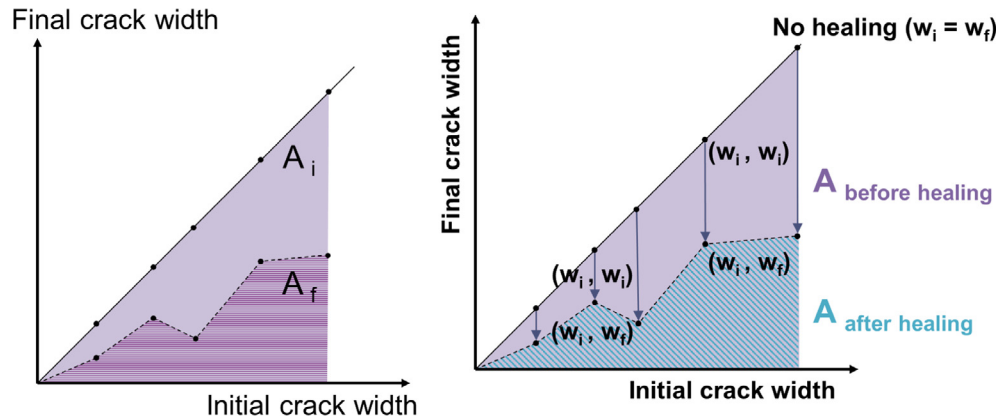

Fig. 5. Area under the curve when representing initial vs remaining crack width. Method used in [76,155,181].

The aforementioned parameters are commonly used in the expression of Eq. (1) to quantify crack closure, where  $w$  is the specific parameter used for the evaluation, either crack width, area or volume, and subscript  $t$  refers to the specific healing time at which the crack closing evaluation is performed.

$$\text{Crack closure (\%)} = 1 - \frac{w_t}{w_{\text{initial}}} \quad (1)$$

#### 4.1.4. Correlations between different crack width measurements

The correlations between different crack width/area parameters have been checked in a few studies (Ferrara et al., 2016c); [141], showing the coherence of the measurements, even though some dispersion is produced due to the natural variability of crack width and the three-dimensional features of the crack. Achieving almost total crack closure is relatively frequent in the cited researches.

#### 4.1.5. Healable crack width

Depending on the type of healing, different crack widths can be closed and thus different crack widths need to be investigated.

Autogenous healing may lead to different healing of cracks as the mixture design may vary a lot. The mixture may contain supplementary cementitious materials, high cement contents, low water-to-binder ratios, etc. In literature, a range of possibilities of total healing can be found, ranging from a few tens  $\mu\text{m}$  [75,146], to 100  $\mu\text{m}$  [219] and even 300  $\mu\text{m}$  [218]. This healing also depends on the total allowed time of healing and its conditions. Generally, it is accepted that only narrow cracks are likely to be completely healed and that only partial healing is feasible in wider cracks. In strain-hardening cementitious materials, for example, it is documented that healing in wet/dry cycles can lead to closure of cracks up to 30–50  $\mu\text{m}$  and partial closure up to 150  $\mu\text{m}$  [97,98,158]. When using superabsorbent polymers (SAPs), this autogenous healing is stimulated and promoted up to 150  $\mu\text{m}$  [158,161]. In bacteria-based approaches, several hundreds of  $\mu\text{m}$  to mm cracks are able to close [1,79,177,188,189,191,192]. When using mineral admixtures such as geopolymers, cracks up to 150–200  $\mu\text{m}$  are able to close [3] or even larger cracks up to 300–500  $\mu\text{m}$  are able to close when using crystalline admixtures [140,141,46] – which can be encapsulated or not [83,137] – or expansive agents [93,152]. When using encapsulated foaming agents such as polyurethanes, cracks up to several hundreds of  $\mu\text{m}$  can be closed [178,179].

In order to study the effects of the crack width, different cracks can be made with the methods previously described. As the conditions also play a role, different healing conditions need to be inves-

tigated. One needs to be careful when comparing results as different conditions may lead to different degrees of healing.

As remarked above, visual healing by means of microscopy does not always mean that the complete specimen is healed. The extent in the interior of the specimen again depends on the type of healing studied. Most of the autogenous healing products, for example, are mainly precipitated from 0 till 800–1000  $\mu\text{m}$  inside the crack, as studied by means of X-ray computed micro-tomography [161,162] and polished thin sections [161]. The crystals are abundantly present in the region 0–150  $\mu\text{m}$  below the surface [40]. As the crack is physically sealed at the surface from intruding water, the crystallization slows down in the interior of the crack. Less healing products are therefore found in the interior of the sample as the carbon dioxide will preferably be used at the surface where it dissolves in the water layer during the wet/dry cycles. Also Jonkers [79] showed that the healing mainly occurred near the crack mouth, and especially near the crack rims. The precipitation at the crack rim is the result of calcium hydroxide using the carbon dioxide from intruding water in the crack, and afterwards the remaining calcium hydroxide would dissolve and diffuse out of the crack into the bulk water. There it will react with carbon dioxide present near the crack rim resulting in the precipitation of calcium carbonate [79,155].

## 4.2. Tests and methods based on the recovery of durability properties

Several test methodologies have been set-up to assess the effects of healing through the recovery in durability related properties, including, e.g., permeability and sorptivity measurements as well as resistance to chloride penetration (see Table 2).

### 4.2.1. Permeability

The permeability of concrete is strictly correlated to the rates at which liquids and gases diffuse through it. It is worth remarking that two order of magnitude difference in viscosity hold between liquids and gases [16]. Two versions of the test have been used for the evaluation of permeability of cracked and healed concrete specimens:

- Evaluation of the decrease in pressure (water-height) after a certain period;
- Evaluation of water flow passing through the specimen during a certain period.

For the first group, the water permeability test set-up and methodology has been based on the proposal by Aldea et al. [7] and Wang et al. [187]. First, cylindrical specimens are glued into

a PVC ring by means of an epoxy resin and then vacuum saturated with tap water. Afterwards, the specimens are placed in the test set-up, and tubes filled with water are inserted into their top and bottom edge faces [177–179,110,158]. During the test, water permeation through the samples causes a drop in the water height in a pipette with a scale on top of the system [177,178]. From periodic measurements of water height, the water permeability coefficient  $k$  is determined by means of Eq. (2):

$$k = \frac{aT}{At} \ln\left(\frac{h_0}{h_f}\right) \quad (2)$$

where  $a$  = cross-sectional area of pipette ( $\text{m}^2$ ),  $A$  = cross-sectional area of specimen ( $\text{m}^2$ ),  $T$  = specimen thickness (m),  $t$  = time (s),  $h_0$  and  $h_f$  = initial and final water heads (cm), respectively.

When this coefficient  $k$  becomes constant, it is assumed as the water permeability coefficient for that sample [177,178]. It is worth remarking that the values of permeability of un-cracked ordinary and high performance concretes are usually in the range of  $10^{-12}$ – $10^{-14}$  m/s [16].

With reference to the second group, Edvardsen [218] used a test set-up able to produce tensile cracks and to expose concrete specimens to water pressure to evaluate the water flow going through the cracks. This method was also used successfully by Homma et al. [68]. Roig-Flores et al. [140,141] proposed a similar version, easier to be implemented, which is based on the standard test to measure water depth penetration through concrete specimens (EN 12390-8), but measuring the water flow instead.

Formia et al. [51], following the same principle, have proposed a very simple test set-up, in which a 50 mL syringe filled with water is attached with silicone above the healing area; the water height in the syringe was monitored during 48 h at determined time intervals (every 30 min during the first 3 h, then every hour up to 24 h and finally, after 48 h). The plot of the residual volume of water in the syringe as a function of time is the output of this test.

In the recently finished European project HEALCON, a water flow test was developed (Fig. 6) [64,63,172]. The prismatic mortar prisms ( $40 \times 40 \times 160 \text{ mm}^3$ ) to be tested are prepared with a cast-in longitudinal hole ( $\varnothing 5 \text{ mm}$ ) at mid depth and over the whole length of the specimen. After performing a crack-width controlled three-point bending test, the specimens are saturated by water submersion. Then, the crack is sealed at the side surfaces with aluminium tape. The hole is sealed at one end with methyl methacrylate glue, and at the other side a connection is made with a plastic

tube. This tube is connected to a water basin, positioned with the water level at 500 mm above the mid depth of the specimen. The water flowing through the hole and the crack is captured on a scale with an automated registration system, allowing the monitoring of the water flow in time. After healing, a second water flow test is performed to evaluate the healing efficiency. For healing mechanisms that need some time, like bacterial healing, this second measurement can be performed on the same specimens.

As for the representativeness of test measurements, it is worth remarking, as a general reference, that, if healing takes place immediately, like in the case of several polymeric encapsulated healing agents, the measurements before and after healing need to be performed on different samples containing cracks of similar width. In case of the use of (not encapsulated) superabsorbent polymers, the first measurement allows the evaluation of the immediate sealing action, while the second measurement, after healing, evaluates the longer-term healing in combination with the immediate sealing. In addition, the test can be performed under increasing water pressure by replacing the open water basin by a sealed container with pressure adjuster [64,63].

For the evaluation of self-healing by means of this family of tests, two main options have been proposed, using expressions similar to the one used for crack closing. The basic structure is the same: Eq. (3), proposed in HealCON, uses data from companion unhealed specimen as reference, while Eq. (4), as proposed by Roig-Flores et al. [140,141] uses the same specimen and compares the water flow through it before and after healing:

$$SH_1 = \frac{W_{unhealed,t} - W_{healed,t}}{W_{unhealed,t}} \quad (3)$$

$$SH_2 = \frac{W_{initial} - W_{final}}{W_{initial}} \quad (4)$$

where  $SH$  is Self-Healing index,  $W_{unhealed,t}$  is the amount of water passing through the specimen's unhealed crack at time  $t$ ,  $W_{healed,t}$  is the amount of water passing through the specimen's healed crack at time  $t$ ,  $W_{initial}$  is the amount of water passing through the target specimen before healing and  $W_{final}$ , after healing. Gruyaert et al. [63,64] provided extensive explanation on the use of the aforementioned equations in the case of healing engineered through the use of SAPs.

The use of a companion unhealed specimen allows to discern the differences produced by aging of concrete. However, since in this type of test the size of the crack will have the greatest influence on the water flow, Eq. (4) could also be interestingly employed to compare the same specimen before and after the healing process, in order to compensate for the uncertainties due to the variability of crack width.

Edvardsen [218] has proposed the following equation to estimate water flow from crack width:

$$q_0 = 740 \cdot I \cdot w_m^3 \cdot k_t \quad (5)$$

where,  $q_0$  is the initial water leakage per visible unit crack length ( $l/m$ ),  $I$  is the hydraulic gradient (m of water head / m),  $w_m$  is the crack width (mean value) at the surface (mm),  $k_t$  is a factor accounting for water temperature (if different from  $20^\circ\text{C}$ ). This equation was also checked in a different setup by Snoeck [158] and by Roig-Flores et al. [140,141] considering the differences in specimen shape and the unknown geometry of the in-depth crack. Reliable correlation was obtained for measurements referring to both unhealed and healed specimens and thus between the healing performance in terms of both the crack width/area (Eq. (1)) and water flow (Eq. (4)) (Fig. 7).

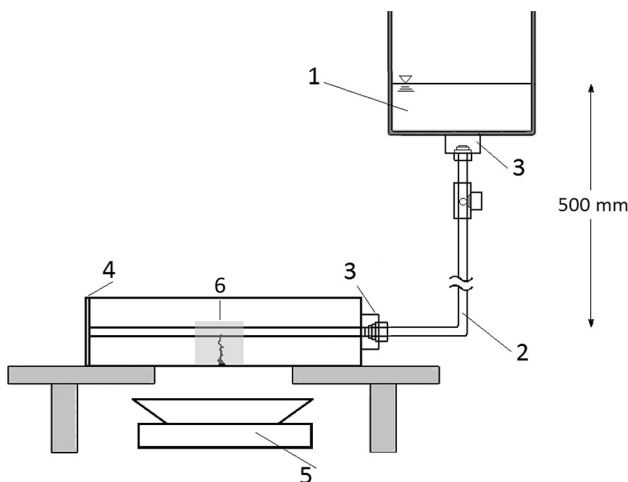

Fig. 6. Test set-up for the water flow test under low pressure. (1) water container, (2) plastic tube, (3) connector, (4) sealing, (5) scale, (6) sealing with aluminium tape [64,63].

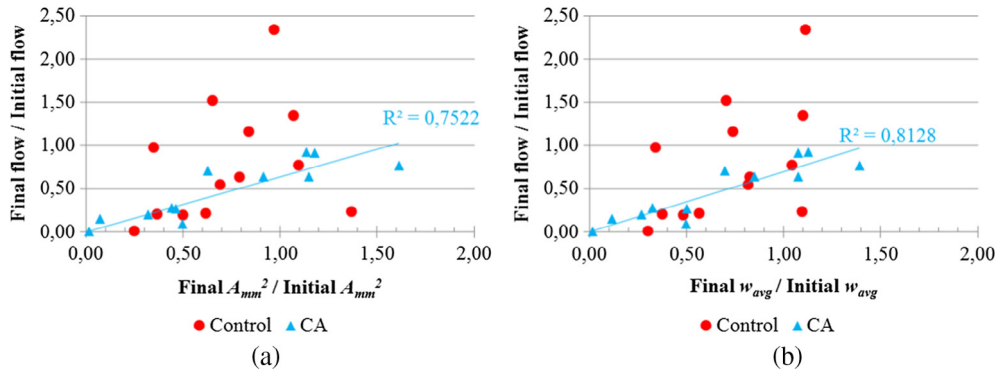

Fig. 7. 3-Relation between water flow ratio and estimated crack area  $A_{mn}^2$  ratio (a) and averaged crack width  $w_{avg}$  ratio (b) for a control concrete mixture and a concrete containing crystalline admixtures (CA) from Roig-Flores et al. [140].

#### 4.2.2. Sorptivity

The sorptivity is an indicator of the concrete ability to absorb and transmit liquid by capillary suction [142]. As illustrated by de Rooij and Schlangen [29], measurement of the capillary water absorption for cracked concrete specimens with and without healing can be used to evaluate the crack healing efficiency. To this aim, the specimens are first placed in an oven to remove the moisture (e.g. at  $50 \pm 5^\circ\text{C}$  for 3 days as mentioned by Şahmaran et al. [146]; or at  $40^\circ\text{C}$  as mentioned by [188]). Then, the area adjacent to the damaged zone is covered with an adhesive aluminium tape, leaving only the crack face exposed to capillary suction (not more than 10 mm in width) [9]. The specimens are then placed on two rigid non-porous supports in a container with water and with only the lower  $2 \pm 1$  mm of the specimens immersed in water. The specimens are weighed to determine the weight gain over time, at prescribed time intervals.

Alghamri et al. [9] performed measurements every 4 h, whereas Feiteira et al. [41] and Pereira Gomes De [11] performed more frequent measurements initially (i.e. at 5 min, 30 min, 1, 2, 3, 4, 6 and 8 h) based on the test procedure described in the European standard EN 13057. Even more detailed measurements were taken by Van Belleghem et al. [175], who measured the capillary sorption at 5 min interval for the first half an hour and then at 30 min interval until 8 h after the start of the sorption test. After that, the specimens were left in the trays and the mass was recorded again every 24 h of exposure to the water, until a total exposure time of 96 h.

The cumulative absorbed volume per unit area  $i$  ( $\text{mm}^3/\text{mm}^2$ ), defined as the change in mass (g) divided by the water exposed area of the test specimen ( $\text{mm}^2$ ) and the density of water at the recorded temperature ( $\text{g}/\text{mm}^3$ ), is plotted against square root of time,  $\sqrt{t}$  ( $\text{min}^{0.5}$ ). The slope of the obtained line gives the sorptivity index (S) of the specimen [9].

In order to evaluate healing from sorptivity test results, the following expression has been proposed:

$$SH = \frac{S_{unhealed} - S_{healed}}{S_{unhealed} - S_{uncracked}} \quad (6)$$

where  $S_{unhealed}$  is the sorptivity index for the cracked and unhealed specimen,  $S_{healed}$  is the sorptivity index for the cracked and healed specimen and  $S_{uncracked}$  is the sorptivity index for the uncracked reference specimen.

Recently the calculation of the sorptivity index from the square root of time has been questioned, Villagrán Zaccardi et al. [185] having reported that the water absorption linearly relates to the fourth root of time. The reliability of the absorption test also has some drawbacks. If a crack is only partially healed, the capillary rise in the resulting narrow crack may be higher than for the initially wider crack. Hence, the desirable effect of partial healing

may not be noticed from the weight measurements. Further, when sealing using super-absorbent polymers (SAPs), the SAPs at the crack faces will take up water, leading to mass increase, and would block water flow through the crack, but this will not be noticed from the water absorption measurements.

#### 4.2.3. Gas permeability

Gas permeability based on liquid methanol as the gas source or oxygen taken from a gas tank was studied by Yang et al. [206] and Mechtcherine and Lieboldt [110] respectively, in order to determine the permeability coefficient of mortar specimens cracked by means of splitting tensile tests. 10 mm-thick cylinders, with a diameter equal to 50 or 100 mm, were vacuum-dried at room temperature for 24 h to remove the moisture within specimens and were then placed and sealed on the top of a cell with epoxy sealer to avoid leakage of methanol vapour. The initial weight of the whole specimen setup, including the cell, liquid methanol, disk specimen and epoxy sealer, was measured at the beginning of the test. The values of mass variation vs. time due to the vaporization of methanol liquid, produced by a water bath whose temperature was kept constant at  $40^\circ\text{C}$  during the test, were continuously recorded until a steady-state mass loss was reached. The permeability coefficient is then calculated by means of Eq. (7)–(10):

$$P_V = 10^{(8.0809 - \frac{1582.2}{239.76+T})} \quad (7)$$

$$n = 10^{-7} (4.7169T^{0.618} - 99e^{-8.7593 \times 10^{-4}T} + 94e^{-7.916 \times 10^{-3}T} + 5) \quad (8)$$

$$Q = \frac{266 \times 10^{-3} m'}{10^{(8.0809 - \frac{1582.2}{239.76+T})} T} \quad (9)$$

$$k = \frac{2LnP_2Q}{A(P_1^2 - P_2^2)} \quad (10)$$

where  $P_V$  is the absolute pressure of vapour ( $\text{N}/\text{m}^2$ ),  $T$  the absolute temperature (K),  $n$  the dynamic viscosity ( $\text{Ns}/\text{m}^2$ ),  $Q$  the volumetric flow rate ( $\text{m}^3/\text{s}$ ),  $m'$  the rate of mass loss ( $\text{g}/\text{s}$ ),  $k$  the intrinsic permeability coefficient ( $\text{m}^2$ ),  $P_1$  the inlet pressure ( $\text{N}/\text{m}^2$ ),  $P_2$  the outlet pressure ( $\text{N}/\text{m}^2$ ),  $L$  the length of the sample (m) and  $A$  the cross-sectional area perpendicular to the flow direction ( $\text{m}^2$ ).

Yang et al. [206] employed the test to evaluate the healing efficiency of silica gel shell micro-capsules containing either methylmethacrylate or triethylborane oil core. Damage was induced in the specimens by loading them, at 3 or 30 days age, at 80% of their compressive strength and healing was evaluated by comparing the gas permeability coefficients, as from measurements taken 24 h after the damage induction on healed and reference control

specimens. Anyway, Yang et al. [206] provided no comparison between healing in terms of gas permeability coefficient and crack sealing visually observed, if any.

Yildirim et al. [213] investigated the influence of cracking and self-healing on the gas permeability of Engineered Cementitious Composites (ECC). Though application of pre-loading led to significant increases in gas permeability, so that even microcracks of less than 50  $\mu\text{m}$  caused a gas permeability coefficient fifty times higher than that of sound specimens, the crack-healing resulted in a recovery in the same permeability up to 96% after only a month through proper material design and conditioning.

#### 4.2.4. Chloride penetration

Chloride ion penetration in concrete, including cracked concrete, is measured through different techniques, including chloride diffusion upon immersion and chloride migration based on a migration cell or through rapid chloride migration.

Few studies exist on the effect of cracking on the natural chloride ion diffusion. Test were performed on partially cracked specimens [208,201], as well as on specimens with through-thickness single and multiple cracks [6,32,116,91]. Akhavan et al. [6] showed that the diffusion coefficient is strongly dependent on the crack volume fraction and that the crack tortuosity slightly reduces the ion diffusion through the crack. Djerbi et al. [32] showed that the diffusion coefficient through the crack becomes constant when the crack width is higher than (about) 80  $\mu\text{m}$ . Win et al. [201] highlighted that the chloride diffusion in both cracked and uncracked concrete increases with the w/c ratio.

While there is lack of experience with reference to normal chloride diffusion, the rapid chloride-ion permeability test (AASHTO T277 “Standard method of test for rapid determination of the chloride permeability of concrete” and ASTM C1202 [12], “Standard test method for electrical indication of concrete’s ability to resist chloride ion penetration”) has been widely employed to characterize the durability of concrete with reference to its ability of providing adequate protection to reinforcing bars against chloride induced corrosion. It provides an idea of the interconnectivity of the fine pores in concrete that are too fine to allow water flow [10] and hence to be discriminated from water flow/water permeability tests. Experience has revealed good correlation between the water permeability and rapid chloride ion permeability in concrete with a W/C greater than 0.40.

The efficiency of self-healing from rapid chloride migration test has been studied by Wang et al. [190], Jacobsen et al. [75], Darques et al. [217], Sahmaran et al. [147]. Wang et al. [190] employed the test to check the healing effectiveness of capsules with urea formaldehyde shell and epoxy healing agent core in cylinder specimens damaged at 50% of their compressive strength. A 0.2 mol/L KOH water solution (as anolyte) and a mixed water solution (with 5% NaCl and 0.2 mol/L KOH, as catholyte) with an applied potential of 30 V at room temperature for 24 h. Then, the specimens were split using a testing machine and coloured with a 0.1 mol/L  $\text{AgNO}_3$  water solution, to highlight chloride ions penetration into the sample. The chloride ion migration coefficient was calculated according to Eqs. (11) and (12):

$$D_{RCM} = 2.872 \cdot 10^{-6} \frac{T \cdot h (x_d - \alpha \sqrt{x_d})}{t} \quad (11)$$

$$\alpha = 3.338 \cdot 10^{-3} \sqrt{T \cdot h} \quad (12)$$

where  $D_{RCM}$  is the chloride ion migration coefficient ( $\text{m}^2/\text{s}$ ),  $T$  is the average temperature of the anolyte (K),  $x_d$  is the depth of chloride ion migration (m),  $t$  is the time during which electricity was applied (s),  $\alpha$  is a supplementary variable, and  $h$  is the height of the specimen (m).

The healing was evaluated by comparing the chloride ion migration coefficient, calculated as above, for specimens immediately after pre-damaging and after 3 days curing at 20 °C and RH > 90%. No comparison between healing in terms of chloride ion migration coefficient and observed crack sealing was provided.

Jacobsen [75] used a 3 mol NaOH solution and applied a 60 V potential. The total chloride flux  $J$ , ( $\text{mol}/(\text{cm}^2 \cdot \text{s})$ ) during migration was calculated using the Nemst-Planck equation. Self-healing of cracked concrete for three months in water led to a significant reduction in rate of chloride migration, ranging between 28 and 35% as compared to migration in freshly cracked specimens.

As already remarked above, chloride penetration depths determined using the colour change boundary test or determination of chloride diffusion coefficients and chloride migration coefficients through chloride profiles through the specimen depth have been also reported, also complementing aforementioned investigations.

The colour change boundary test is a very simple and quick method to measure the free chloride penetration depth in concrete. In this method, an aqueous silver nitrate ( $\text{AgNO}_3$ ) solution with a concentration of 0.1 mol/L is sprayed on the freshly fractured cross-section surface of concrete forming a distinguished boundary with white and brown areas. An  $\text{AgCl}$  white precipitate is formed by silver ions reacting with the chloride ions whilst a brown precipitate is formed when the silver ions react with the hydroxyl. The colour change boundary can be measured by means of image analysis software. Cylindrical specimens, un-cracked and also pre-cracked in splitting, can be employed, immersed in chloride solutions or chloride-rich environments. The bottom and lateral surfaces are often sealed using, e.g., an epoxy to allow for chloride penetration perpendicular to the uncoated surface. After scheduled immersion times, specimens are split open and the test solution is sprayed on the split crack surfaces. The penetration depth from the exposed surface or chloride affected areas and also the chloride ingress in the direction perpendicular to the crack can be measured.

In addition, chloride penetration profiles can be determined using potentiometric titrations using powder collected at different depths through the samples, through the crack and in zones away from it. The results can also be used for the determination of the chloride diffusion coefficient referring also to Fick’s laws of diffusion.

The aforementioned techniques were employed by Ismail et al. [74], who performed chloride penetration tests on cracked mortar specimens up to the duration of 2 years after cracking, as well as by Sahmaran et al. [144], Sahmaran [143] and Maes et al. [108], who performed chloride penetration tests respectively on ECCs and cracked mortar specimens prepared through different methods. All group of authors confirmed the effectiveness of crack sealing in reducing the chloride penetration as a function of initial crack opening and mortar pre-cracking age. Ismail et al. [74] further reported that no chloride diffusion occurs in cracks up to 30  $\mu\text{m}$  wide whereas Sahmaran [143] found effect of crack width on chloride diffusion to be marginal for cracks up to 135  $\mu\text{m}$ .

Ferrara et al. [50] correlated the amount of the surface crack sealing on cylinders pre-cracked in splitting (up to 90% of the splitting tensile strength) with the chloride penetration depth as measured through the colour change boundary test. Specimens were subjected to daily wet and dry cycles in a 165 g/l NaCl solution. Interestingly, the authors reported that specimens undergoing crack sealing larger than 90% featured values of the chloride penetration depths in the upper bound range of the values measured for companion un-cracked samples. This highlights the importance of investigating also aspects such as the binding of chlorides through the sealed cracks, in order to provide relevant information for service life predictions and effects of self-healing and its efficiency.

**Table 3**  
Review of test methods to determine healing and recovery of durability properties after repairing (adapted from: Van Tittelboom and De Belie [182], Souradeep and Kua [164]).

Type	Test	Purpose	Limitations
Recovery of water and air tightness (durability features)	Water permeability (low/high pressure)	Water permeability coefficient can be determined by flow of water through healed cracks	Effectiveness is dependent on how the cracks were introduced
	Sorptivity	Concrete's ability to absorb and transmit liquid through it by capillary suction	Needs a reference sample as water uptake happens also from the undamaged matrix. Absorption "driving force" under debate (capillary forces in smaller cracks?). Multidimensional effects in water uptake not adequately taken into account.
	Air permeability	Flow rate of air after healing has occurred measures the resistance against moisture/foreign substance penetration through (healed) cracks.	Very sensitive to the specimen composition: methanol can dissolve organic polymers used as healing agents.
	Chloride diffusion and penetration	Measurement of resistance against chloride penetration.  Relevant and applicable for coastal structures or structures exposed to de-icing salts.	Good correlation between the water permeability and rapid chloride ion permeability so far demonstrated only for specimens with w/c higher than 0.40.

A summary of the test methods employed so far to determine healing through durability related tests is reported hereafter in Table 3.

#### 4.3. Tests and methods based on the recovery of mechanical properties

In the case of methods based on the recovery of durability properties, the comparison between pre-cracked or reference specimens and healed ones provides a straightforward interpretation of the occurred healing process, if any. As a matter of fact, what is measured is in most cases a "passage through the crack" and hence a property of the crack. On the other hand, methods based on the recovery of the mechanical properties provide a measure of the "structural" behaviour of a specimen, on which the healed cracked cross-sections plays a dominant role.

In order to evaluate healing through the recovery of mechanical properties, the same test performed for pre-cracking is repeated after the scheduled healing period under the selected exposure conditions. The comparison between the mechanical property at the moment of pre-cracking and after the scheduled healing period is assumed as an indicator of the healing effectiveness. It is worth remarking that mechanical properties in concrete do evolve with time also without healing, mainly in peculiar exposure conditions which are also highly conducive to healing (including, e.g., water, high RH). It is hence of the utmost importance to discriminate between what is healing and what is continuing bulk hydration. In this framework, not only availability of reference un-cracked specimens undergoing the same curing as the healing ones is mandatory, but it can also be helpful to correlate between the recovery of different mechanical properties (strength, stiffness, strain and deformation capacity) mutually and with respect to crack closure. With reference to this issue, it has for example been shown that in the case of autogenous healing, at least a 60% crack closure has to be achieved before registering any appreciable recovery of strength and stiffness [43,47]. Similarly, comparing crack closure with water permeability, it has been shown that specimens were more likely to exhibit higher crack closure ratios than sealing ratios [141]. These results suggest that crack closure is the first preliminary step before achieving the recovery of any mechanical and/or durability properties as well as that considering only crack closure as a healing indicator may lead to overestimate the material healing capability [64,63].

"Purely" mechanical tests have been complemented with non-destructive ones, such as Ultrasonic Pulse Velocity tests, which

can also separately investigate zones of the specimen outside the crack [48] or directions other than the pre-damaging/loading one [27]. This information may be useful to discriminate between continuing bulk hydration and crack/damage healing. In the case of fibre reinforced cementitious composites, further information was also garnered complementing, e.g., flexural or direct tension tests with fibre–matrix bond tests. In this way recovery of macro/meso-scale mechanical properties could be associated with micromechanical information about the effects of healing on the recovery/evolution of the fibre–matrix bond.

##### 4.3.1. Tests and methods based on ultrasonic wave propagation

An important contribution to the overall comprehension of the self-healing mechanisms in cementitious materials can be achieved through the implementation of proper non-destructive methods, such as those based on ultrasonic wave propagation. Ultrasonic techniques have been extensively used over time to detect internal defects, cracks or voids in high-attenuation materials such as concrete and mortars. Therefore, they are expected to be effective also in characterizing the reverse process of crack closure and performance recovery due to self-healing. Furthermore, being non-destructive, they allow to check the effectiveness of the proposed self-healing technologies directly on-site, allowing a virtually continuous monitoring of the material characteristics in time.

**4.3.1.1. Ultrasonic pulse velocity tests.** So far, one of the foremost ultrasonic techniques used worldwide for the assessment of self-healing in cementitious materials is based on the determination of the ultrasonic pulse velocity (UPV). Reference standards can be found in ASTM C597 and EN 12504-4 [37]. The working principle is fairly simple and easily implementable: a pulse of longitudinal vibrations is produced by a piezoelectric transducer (with natural frequency normally ranging between 20 kHz and 150 kHz) that is acoustically coupled to one surface of the concrete specimen. After traversing a known path length in the concrete, the pulse of vibrations is converted into an electrical signal by a similar transducer working as a receiver. The transit time of the pulse is measured by proper electronic timing circuits, thus allowing to estimate an average value for the pulse velocity along the travel distance. Variations in UPV can be associated to the presence and depth of cracks along the wave path.

Following this principle [90], the method has been employed both in direct (i.e. sensors on opposite faces of the samples, with

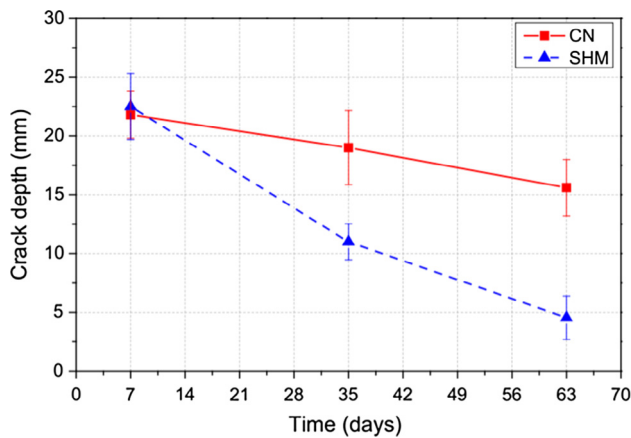

Fig. 8. Evolution of crack depth as estimated via the Ultrasonic Pulse Velocity Method in control (CN) and self-healing specimens made with sodium-silicate-impregnated lightweight aggregates (SHM) [9].

wave propagating perpendicular to the crack plane) and indirect (surface) transmission modes. The effectiveness of self-healing has been evaluated in different categories of cement based materials, either autogenous/stimulated or engineered, via crystalline admixtures [43,48], bacteria-based repairing agents immobilized in silica gel, as also compared to external repair techniques using grout and epoxy [177], non-ureolytic bacteria [203,200] and sodium silicate entrapped in double-walled polyurethane/urea-for maldehyde microcapsules and in lightweight aggregates coated with polyvinyl alcohol [115,9]. Damage/healing indicators, based on UPV ratios and change in transit time respectively, were computed and correlated, with good agreement, with the mechanical recovery under flexural actions [43,49,203,200] as well as with water permeability and visually inspected crack closure [177]. Interestingly, both Mostavi et al. [115] and Alghamri et al. [9], through the analysis of TOF change, quantified also the change in crack depth as due to self-healing, (see Fig. 8 for example) correlating it with recovery in strength and durability properties. Additional case studies of self-healing systems characterized through UPV measurements have been reviewed by Ahn et al. [4].

Despite their widespread use and successful results in the studies cited above, ultrasonic techniques based on the determination of UPV are not free from drawbacks, which may limit their use in several practical applications. In particular, there are disruptive effects due to the unavoidable variability in the coupling between the sensor and the specimen surfaces, because of moisture content, temperature changes, presence of reinforcing bars and, mostly, contact points or stress states inducing partial crack closure. These may result in unreliable measurements and estimate of crack depth.

**4.3.1.2. Test methods based on Rayleigh waves.** Because of the reasons exposed above, some researches resorted to other ultrasound-based diagnosis techniques for the evaluation of crack healing in cementitious materials. Aldea et al. [8] and Aggelis et al. [2] performed transmission experiments using Rayleigh waves to investigate surface-breaking cracks/defects and their repair due to autogenous healing or epoxy injections respectively. Ultrasonic vibration sensors were positioned on the concrete surface at various distances from the excitation source and from the crack: the received transient response (which is dominated by the surface wave arrival) allowed the detection of the transmission properties. As the waves propagate between two receivers, a portion of the total signal is transmitted and the rest is attenuated, with major attenuation phenomena depending on the presence

of the crack in between. Therefore, the ratio of wave amplitude in cracked (repaired) concrete over the amplitude in sound material was used as an evaluation parameter to assess the healing process. Good results were obtained when considering either epoxy injection or continuous hydration as the activation mechanisms for healing. Nonetheless, as reported by Aldea et al. [8], in the case of autogenous healing the healing-related recovery in wave transmission properties was quantitatively less significant than in other, e.g., durability related properties, such as the reduction in permeability coefficient.

**4.3.1.3. Test methods based on ultrasound diffusivity.** Ultrasound diffusivity parameters can also be used to evaluate self-healing in concrete, especially when healing of small cracks is the main concern. Indeed, diffuse ultrasonic techniques have been demonstrated to be particularly sensitive to micro-cracking and micro-structural behaviour [14]. The basic principle underlying these techniques is that waves propagating in strongly heterogeneous media such as concrete (that is characterized by multiple interfaces among cement paste, aggregates, cracks and voids) undergo repeated scattering phenomena that can be quantified as a function of the length scale of the heterogeneity in comparison with the wavelength. The scattering effects are predominant in the intermediate frequency regime, where wavelengths have the same order of magnitude as the size of heterogeneity or when the volume fraction of heterogeneous particles is fairly high. Multiple scattering causes the scattered wave field to lose its spatial and temporal correlations with the incident wave, the process being strongly dependent on the size and distribution of the scatters in the material and on the wavelength (and therefore frequency) of the wave field. A proper model for the diffusion of the ultrasonic energy can be defined, as by In et al. [72], taking into account a diffusivity term and a dissipation term, both dependent on frequency. Based on this model, In et al. [72] explored the progression of autogenous healing in concrete elements containing tensile and flexural cracks and exposed to a simulated marine environment. They found that immediately after cracking, a diffuse ultrasound parameter denoted as Arrival Time of Maximum Energy (ATME) increased, while the diffusivity parameter dramatically decreased from the initial values of the un-cracked control specimens. Conversely, the ATME of cracked specimens decreased significantly after healing, whereas the diffusivity increased with time. A good correlation was found between diffuse ultrasound parameters and crack width, as resulting from microscopic measurements taken on the specimen surface during healing time. It was also observed that diffusivity predicted self-healing trends in a more effective way than the ATME. An exponential-recovery law was proposed to estimate the self-healing rate based on the measured diffusivity.

**4.3.1.4. Coda wave interferometry.** The presence of scattering effects in heterogeneous media has been also the basis for the development of other ultrasonic techniques such as coda wave interferometry (CWI). As previously discussed, elastic waves travelling through a heterogeneous/multiphase medium are scattered multiple times along their path. In this way, they generate slowly decaying waves, called coda waves, that despite their noisy and chaotic appearance are highly repeatable. Therefore, if no change occurs in the medium over time, the waveforms are identical and, conversely, if a change occurs (such as crack formation/ growth), the change in the multiple scattered waves will result in an observable change in the coda waves. Correlation coefficients and velocity perturbation indicators can be defined to characterize such variations in the coda waves. Liu et al. [101] performed experiments to assess the self-healing of internal micro-cracks in cementitious mortars due to bacterial metabolic reactions using CWI and recovery of

compressive strength. As a major conclusion, they found that the velocity change due to continuing hydration in un-cracked samples (or due to autogenous healing in cracked samples without bacteria) was only 4% from day 8 to day 50 (with Urea-Yeast Extract UYE spray), while the total velocity change in cracked samples was about 7%, when UYE-medium was sprayed on bacterial mortar samples. CWI results were in good agreement with those obtained from compressive tests. A similar application of CWI for the assessment of autogenous healing in cementitious materials was carried out by Hilloulin et al. [67].

**4.3.1.5. Nonlinear methods.** Remarkable enhancements are expected from the application of nonlinear methods. Indeed, based on the pioneering work by Guyer et al. [65], it was argued that exploiting the nonlinear dependence of the ultrasonic parameters on the amplitude of the excitation source can considerably increase the measurement sensitivity to damage. Therefore, it can be hypothesized that the nonlinear techniques can be highly effective also in characterizing the reverse process of damage repair due to self-healing. Accordingly, Kim et al. [89] focused on the nonlinear phenomenon of second harmonic generation to explore the microstructure evolution in concrete due to drying-shrinkage and subsequent self-healing (i.e. filling of micro-cracks) induced by accelerated carbonation. They computed a non-linearity parameter based on the ratio between the amplitude of the second harmonic component of the propagating elastic wave and the amplitude of the fundamental component. They observed large changes in the measured nonlinearity parameter during the process of damage generation due to drying shrinkage. On the other hand, they also observed that the increase in the nonlinearity parameter due to the generated micro-cracks was significantly mitigated by both carbonation (up to 64.2%) and the addition of a shrinkage reduction admixture (up to 27%). Hence, they concluded that nonlinear methods such as those based on second harmonic generation have the potential to monitor in a non-destructive way the evolution of micro-cracks over time in hardened concrete. Ait Ouarabi et al. [5] and Gliozzi et al. [56] studied the microstructural evolution in cementitious mortars due to flexural damage and subsequent healing by sodium silicate using linear techniques (transmission and longitudinal resonance modes analyses) and nonlinear techniques (nonlinear elastic wave spectroscopy – NEWS – and scaling subtraction method – SSM). They observed that the flexural damage process was characterized by an ultrasonic phenomenology including a shift of the resonance frequencies, an increase of the attenuation properties and a much higher increase of the nonlinear parameters. A symmetric behaviour was observed during the healing process, when the linear and nonlinear indicators followed a reversed trend that was also accompanied by a remarkable recovery of mechanical strength. An exponential-decay law was proposed to correlate the ultrasonic parameters to the mechanical strength as a function of damage or healing. The results highlighted that the time scales for the evolution of the linear and nonlinear parameters during the healing process differed from each other, thus providing a contribution to understand the complexity of the microstructural changes induced by the interaction between sodium silicate and the cement matrix.

**4.3.1.6. Acoustic emission.** Apart from non-destructive techniques based on the measurement of transmission velocity or other parameters of ultrasound waves, another sound-based technique is Acoustic Emission (AE). This technique has been so far employed to investigate cracking processes in concrete materials and structures [19]. Criteria were also developed relating the structural damage monitored via AE to different levels of “durability threat” [60]. Ref. [180,181,184] have applied acoustic emission analysis for the quantification of autonomous crack healing in concrete by

polyurethane embedded in brittle ceramic tubes. Events due to breakage of the tubular capsules could clearly be distinguished from AE events caused by crack formation. More AE events were noticed upon reloading of specimens with repaired cracks. However, the difference was only significant when epoxy resin was used as healing agent instead of polyurethane. Similar results were obtained by Li et al. [100] with reference to encapsulation based self-healing cement pastes.

Gruyaert et al. [63,64] have compared transmission of S-waves, acoustic emission, vibration analysis and Digital Image Correlation (DIC) results for monitoring self-healing of concrete beams (150 mm × 150 mm × 550 mm). Since the S-wave amplitude of the ultrasonic pulses decreases when the crack width and depth are increasing and increases during curing of the polyurethane in the crack. The breakage of capsules was detected and cracking and healing could be monitored. Moreover, with vibration analysis, the partial recovery in mechanical properties of the self-healed specimens could be detected. It is also worth remarking that AE signals could be used also to evaluate the durability of concrete elements subjected to different loading types.

#### 4.3.2. Mechanical tests

The reconstruction of the through-crack material continuity may result, as a function of the nature of healing and of the experimental boundary conditions analysed in Section 2, into a recovery of the same mechanical property of the material which was affected by the pre-cracking. It is thus of interest to evaluate the healing through its effects on the recovery of selected mechanical properties, which can also help in calibrating a “healing-modified” decaying law for the material properties of interest in a design-wise and life cycle evaluation perspective. In view of the aforesaid statements, the same test employed for pre-cracking is applied to evaluate the healing-related recovery of the investigated mechanical properties.

**4.3.2.1. Compression tests.** Though widely employed to identify the strength class of concrete, compression tests have been scantily employed to assess the healing performance of cement based materials. As a matter of fact, the test is able to induce in the specimens a diffused state of damage, whose entity can for example be correlated to an attained fraction of the compressive strength, rather than a single controlled crack width, which is generally the preferred control parameter to discriminate about healing effectiveness.

The test has been applied by [27,28] to assess the healing capacity of lime mortars, either autogenous or stimulated via crystalline admixtures or engineered through encapsulated lime or cement granules. Damage was induced by loading the specimen at prescribed fractions of the previously determined compressive strength, both in the pre-peak and post-peak regime, and healing was quantified through the recovery of strength, comparing it to the strength developed by companion undamaged specimens subjected to the same curing and healing history.

Differently, Achal et al. [1] verified through the recovery of compression strength the capacity of bacteria to heal 3 mm wide cuts of different depths realized in concrete cube specimens.

**4.3.2.2. Tensile tests.** Since cracks are produced by tensile stresses, direct and indirect tensile tests have been frequently employed to evaluate the effectiveness of healing in cement based materials through the recovery of post-cracking residual load bearing capacity as well as of other tensile and flexural properties.

*Direct tensile tests:* because of the inherent difficulties in performing stable direct tension tests, such tests have been scantily employed to evaluate the healing capacity of plain concrete. Direct tension has been applied by Wang et al. [191–194] on prismatic

mortar specimens via a central reinforcement bar, whose elongation results in multiple cracking of the mortar. Crack closure was measured via optical microscopy to assess self-healing.

However, tensile tests have found pertinent application in the case of HPRCCs, whose signature tensile behaviour not only makes it possible to perform stable tests even without closed loop control, but also makes it of high interest to ascertain the capacity of the same materials to retain and/or recover by virtue of crack healing the aforementioned signature tensile properties in the cracked state. It is worth here remarking that, because of the strain hardening behaviour, pre-cracking/damaging of specimens is generally not performed to a prescribed level of single crack opening but rather to a prescribed average strain level. Because of this, and because of the multiple cracking which occurs, evaluation of healing has been in most cases performed simply through recovery of UPV signals (as explained in Section 4.3.1) [82,123,205–206]. Other authors have also appropriately evaluated the recovery of first cracking and peak strength and stiffness [68,98,145,146,205–207]. A few authors have also assessed the recovery of the strain capacity ([98,205–207] as well as of energy absorption capacity to a prescribed strain level [121,122].

The splitting tensile test has been widely employed for pre-cracking specimens to be employed for durability-recovery healing assessment tests; anyway the strong instability of its post-cracking response has resulted into a scant if not null use for the evaluation of healing through the recovery of mechanical properties. Only a few authors have employed it, with reference to HPRCCs [126,148,149], to evaluate the effectiveness of healing through the recovery of strength, stiffness and deformation capacity.

Interestingly, Şahmaran et al. [148] have also assessed the healing in terms of the number of formed multiple cracks as well as in terms of maximum/minimum and average crack width, whereas Dvorkin et al. [36] and Pourasee et al. [134] employed it to study the sealing of pre-cracked TRC specimens for various textiles and fabric-matrix interface types.

*Other indirect tensile tests:* Cuenca et al. [25] and Cuenca et al. [25] have employed the Double Edge Wedge Splitting Test [34] to assess the healing capacity of Fibre Reinforced Concrete (FRC), both autogenous and engineered via crystalline admixtures, under repeated cracking/healing actions as induced by wet/dry cyclic conditioning of specimens.

**4.3.2.3. Flexural tests.** Three- and four-point bending tests have been, so far, the most commonly employed test to assess the healing capacity of cementitious composites through the recovery of mechanical properties.

Because of the possibility of producing a single crack in a known location and controlling its width, *three point bending tests* have been mostly and almost exclusively employed to evaluate the healing capacity of plain concrete, in case engineered through supplementary cementitious materials [181], crystalline admixtures [43], bacteria [194,137] and lightweight aggregates impregnated with sodium silicates [9]. Healing is evaluated through the recovery of strength and stiffness. Ferrara et al. [43] proposed the calculation of indices related to the recovery of the residual post-cracking load bearing capacity (Index of Load Recovery ILR) and stiffness K (Index of Damage Recovery IDR) (eqs. 13 and 14). They have proposed a method, based on the graphical procedure illustrated in Fig. 9a–b, for indirect evaluation of “equivalent” crack closure from the load vs. crack opening response, defining an index of crack healing ICH (Eq. (15)). Mutual correlation between the indices were also highlighted. It is worth remarking that, as for the recovery of durability related properties, the recovery of mechanical properties seems to proceed slower than the crack sealing.

$$ILR = \frac{P_{\max, \text{reloading}} - P_{\text{unloading}}}{P_{\max, \text{uncracked}} - P_{\text{unloading}}} \quad (13)$$

$$IDR = \frac{K_{\text{reloading}} - K_{\text{unloading}}}{K_{\text{loading uncracked}} - K_{\text{unloading}}} \quad (14)$$

$$ICH = \frac{\text{crack closure}}{\text{initial crack opening}} \quad (15)$$

The same authors, through the evolution of post-cracking/healing flexural stiffness, have proposed a procedure to identify healing related damage growth curves, to be employed as model input.

Ferrara et al. [44,45] and Li and Li [98] have also employed three-point bending tests to assess the healing of FRC through the recovery of post-cracking residual strength and toughness respectively.

*Four point bending tests* have been also widely employed to the purpose at issue in the case of HPRCCs. As a matter of fact, the presence of a zone in the specimen of constant bending moment where cracks can form anywhere, allows the signature multiple cracking of the tensile response of this category of materials to occur as well.

In most of the surveyed studies, healing has been assessed for the aforementioned category of cement based composites reinforced with different types of fibres, ranging from steel and PVA ones to basalt, flax and hemp [157,159] and hybrid steel and sisal [49]. Vegetable fibres may also act as promoters of healing, due to their porous hierarchical microstructure, which enable them to absorb water at a crack and convey it throughout the material.

A few studies on stimulated/engineered healing, via crystalline admixtures [46], superabsorbent polymers [158,159,184] and bacteria [203] have also been documented.

Healing has been assessed through the recovery of flexural strength, stiffness and deformation capacity. Interestingly it was found that whereas the healing rate in terms of strength and stiffness tends to increase upon prolonged exposure to favourable conditions, the healing rate in terms of deformation capacity follows an opposite trend. This may be explained considering a healing-induced improvement of the fibre-matrix bond which results in a higher through-crack stress transfer and in a stress redistribution capacity occurring over a shorter length.

Qian et al. [135,136] have also attempted to evaluate the healing through the amount of cracks formed at new locations, other than the pre-cracking sites, as also documented by Ferrara et al. [49] in the case of hybrid steel and sisal fibre reinforcement. The authors attributed it to the capacity of natural fibres to convey water absorbed at the cracked site throughout the material thus promoting diffused delayed hydration reactions.

Ferrara et al. [46–48] have also discriminated between deflection-softening/hardening behaviour and have highlighted that in the latter case the healing effect on the gross measured recovery of load bearing capacity must distinguish the effects of post-cracking healing from the pre-peak hardening inborn in the material response. They have proposed definitions of healing indices (Fig. 10) and correlated them with the visually observed and quantified percentage of crack closure.

**4.3.2.4. Fibre-matrix bond tests.** Li and Li [98], Kim et al. [88] and Ferrara et al. [50] have evaluated healing through the recovery of fibre-matrix bond, hypothesizing that the observed recovery of tensile and/or flexural properties, as above, is due to both reconstruction of through-crack matrix continuity and improvement of fibre-matrix bond. Healing has been evaluated by comparing the pre-slipping/post-healing load-slip curve with the monotonic ones,

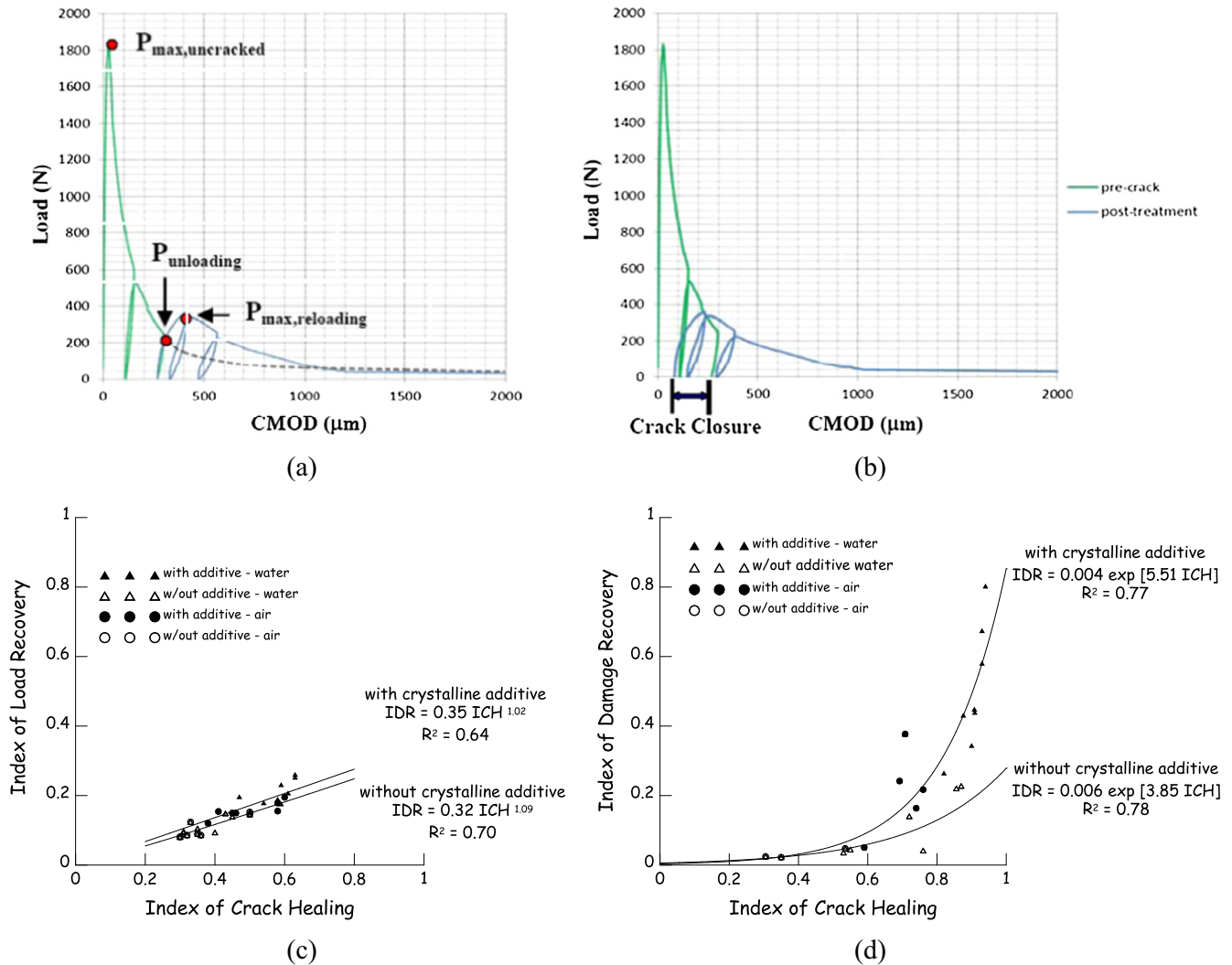

**Fig. 9.** Typical pre-cracking vs. post-conditioning flexural load vs. crack opening response (a) and procedure for effective crack closure evaluation (b). Correlation between Index of Load Recovery as per Eq. (13) (c) and Index of Damage Recovery as per Eq. (14) (d) vs. Index of Crack Healing, as per Eq. (15) [43].

up to complete fibre pull-out, obtained on companion specimens submitted to the same curing and healing regimes and tested at same stages.

**4.3.2.5. Interface shear strength.** Parks et al. [129] evaluated healing through the recovery of adhesion shear strength across a through-cut in a cylindrical sample; the width of the cut was controlled by means of polyethylene spacers.

#### 4.4. Methods of analysis of the healing products

Contemporary methods of instrumented analytics have successfully been applied to characterize the nature of self-healing mineral or petrochemical polymeric products, as hereafter detailed:

- Scanning Electron Microscopy (SEM), most beneficially as Environmental SEM (ESEM) whereby sputtering and exposure to high vacuum of the non-conductive and water-rich samples is avoided for physical reasons, utilising Secondary Electrons (SE) or complementarily Back Scattered Electrons (BSE) [1,3,9,13,18,20,27,38–40,43,44,46,51,53,63,64,68,69,70,71,75,

78,81–83,85,86,94–96,99,103,104,106,108,110,124–126,128,129,133,135,137,145,147,151–153,155,162,165,188,189,191–193,203,216].

- SEM combined with Energy Dispersive X-ray analysis (EDX or EDS) as line-plots or area mappings for qualitative and quantitative elemental analysis [3,20,27,38–40,43,44,46,69,75,78,81,82,88,95,96,99,104,106,108,124–126,128,129,135,137,150,152,153,155,162,192,204,205],
- most beneficially complemented by Powder X-ray Diffraction (p-XRD) of manually extracted self-healing products for qualitative assessment of crystalline phases and consecutive quantification via Rietveld refinement, whereby amorphous and so-called X-ray amorphous species cannot be detected because they reveal no sharp reflexes [3,9,18,20,27,73,69,78,82,83,86,95,104,108,128,133,137,152,153,169,204,211].

Further methods have also been used, including

- Infrared Spectroscopy (IR e.g. in the form of Attenuated Total Reflectance mode Fourier Transform IR, ATR-FTIR) [9,38,39,69,82,83,95,111,137,163], or Raman spectroscopy [68],

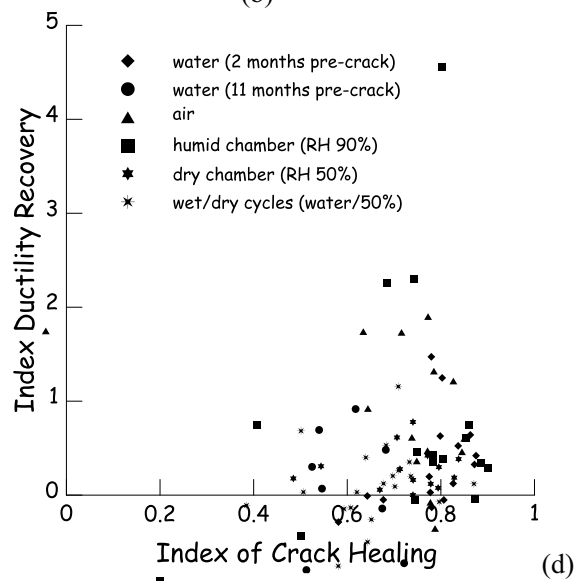
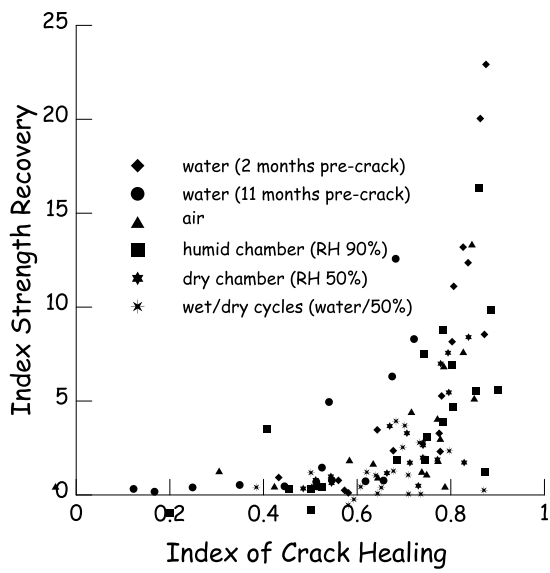
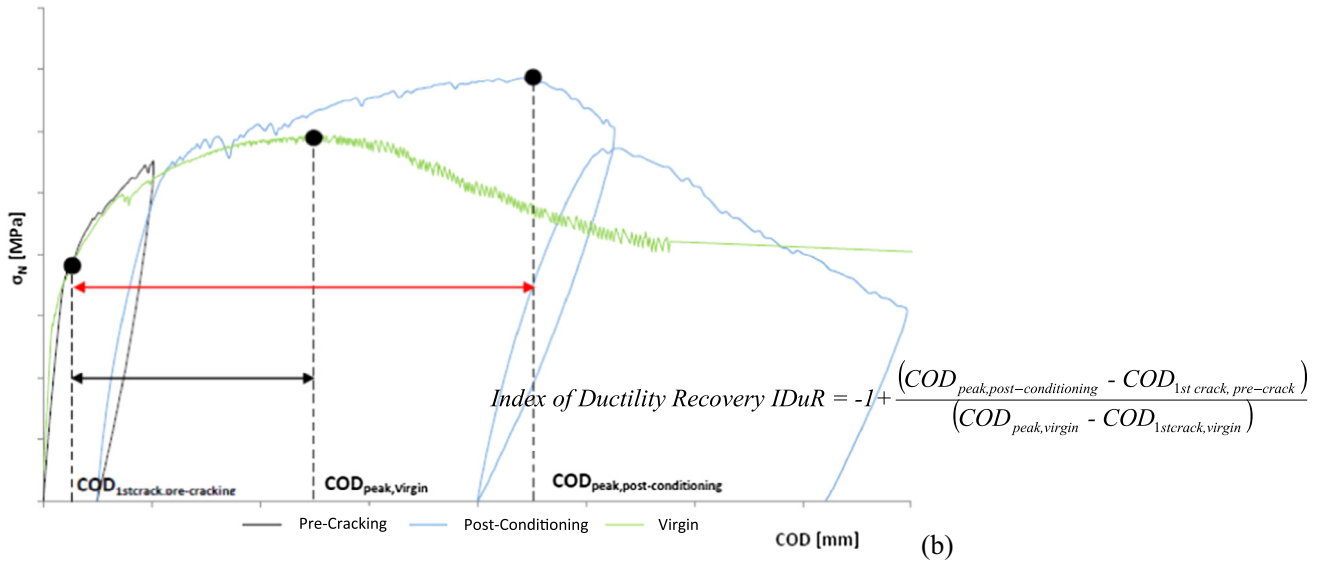
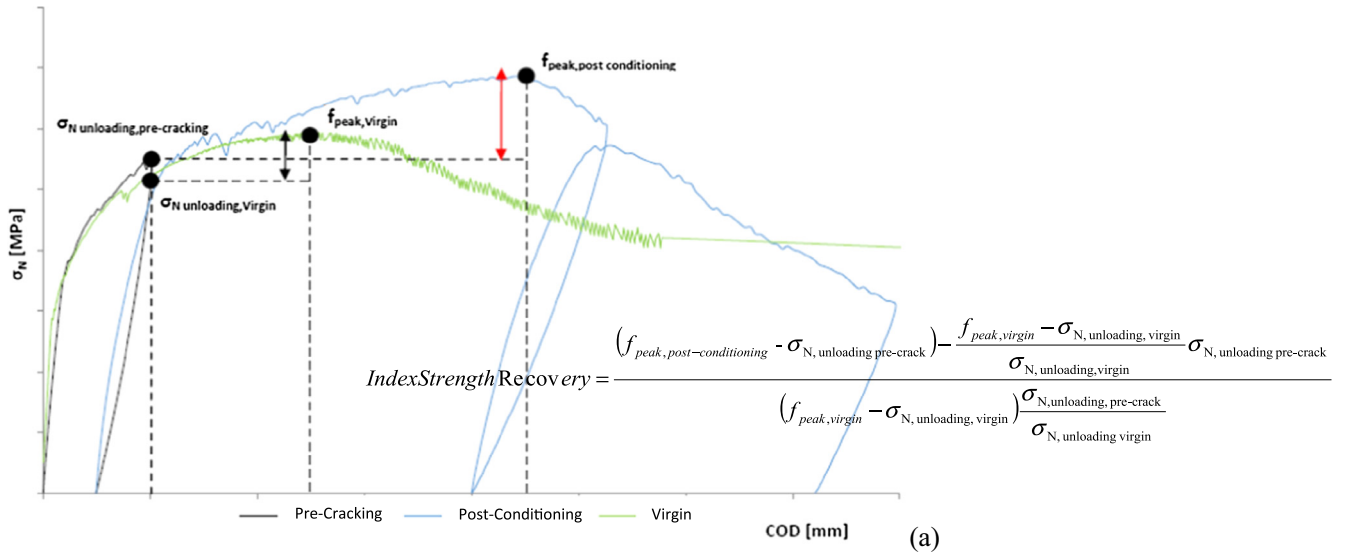
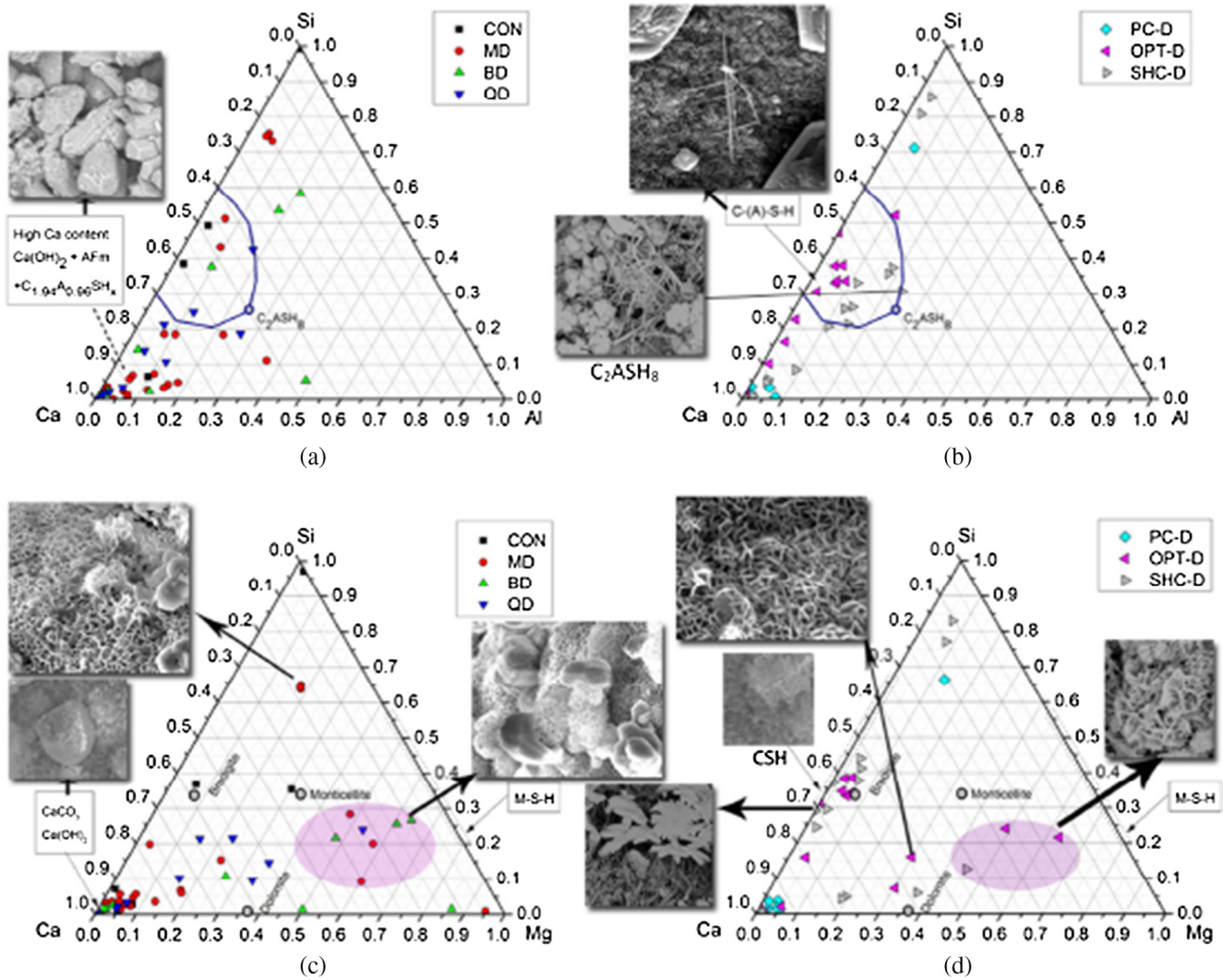

Fig. 10. Proposal for calculation of Index of Strength Recovery (a) and Index of Ductility Recovery (b) for strain hardening HPRC and correlation with Index of Crack Healing (c,d) [46,48].



**Fig. 11.** Self-healing products in concrete mixtures with encapsulated minerals (cf. the table) as quantified by EDX overlaid on SEM images (Nova nano SEM 450, FEI; Bruker QUANTAX EDX Xflash 6|100) [137] (legend for encapsulated minerals: CON: control mix; MD: MgO; PC-D: Portland Cement; BD: Bentonite; QD: Quicklime; OPT-D: MgO, CaO and bentonite; SHC-D: Portland cement with MgO, CaO and bentonite).

- Thermogravimetric Analysis (TGA) in line with Differential Scanning Calorimetry (DSC) [18,95,111,124,133,150,152,158,165,177,188,191,204], or TGA combined with mass spectroscopy (MS) [69],
- Nuclear Magnetic Resonance (NMR) spectroscopy such as proton NMR ( $^1\text{H}$  NMR) [70,132] or Magic Angle Spinning solid state NMR with aluminium or silicon nuclei ( $^{27}\text{Al}$  or  $^{29}\text{Si}$  MAS SS NMR) [73,95], and
- Transmission Electron Microscopy (TEM) [82].

The above mentioned methods, which help in disclosing the chemical or mineralogical nature of the self-healing products, are used to complement observation of crack volume filling efficiency by additional methods, which include (see also Section 4.1 Crack closure quantification):

- permeability measurements, see Section 4.2,
- ultrasonic transmission, see Section 4.3.1,
- acoustic emission analysis [62,181], optical microscopy with original sample surfaces or on petrographic thin sections or polished sections, impregnated with fluorescent resin, whereby

- calcium carbonate gets characteristically coloured upon mineral ascription from classical mineralogy [9,17,38,39,41,53,63,64,68,81,93,94,99,104,108,140,141,149,155,158,181,184,189,205],
- further optical microscopy techniques such as digital 3D optical microscopy to resolve crack depths [88,121],
- Electron Probe Microanalysis (EPMA) [88],
- X-ray Computed Tomography (CT or XCT) [40,52,53,88,103,124,161,162,184,192],
- Mercury Intrusion Porosimetry (MIP) [150,133,195,196], despite its principal physical drawbacks regarding potential discrepancies between the real pore structure and the measurement results [31,114],
- neutron radiography imaging, which method visualises and quantifies water spatially and time resolved [156,176,182].

In general, using only a single method should be regarded as insufficient for thorough identification of self-sealing as well as of products which cause the sealing and healing of the cracks. Most recent publications have thus used multi-method approaches, which are highly recommended for any follow-up studies as well. It has proven most efficient to combine

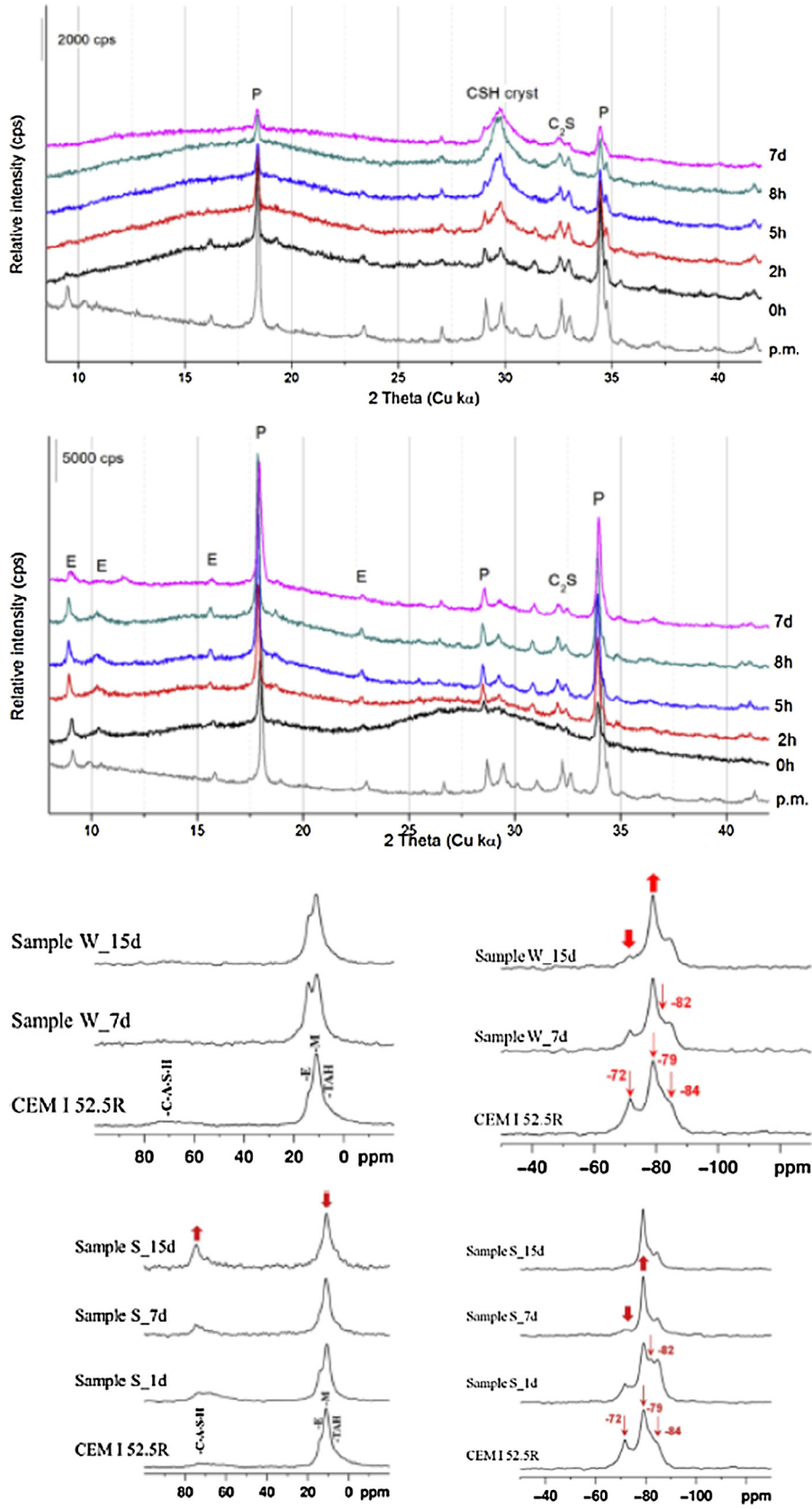
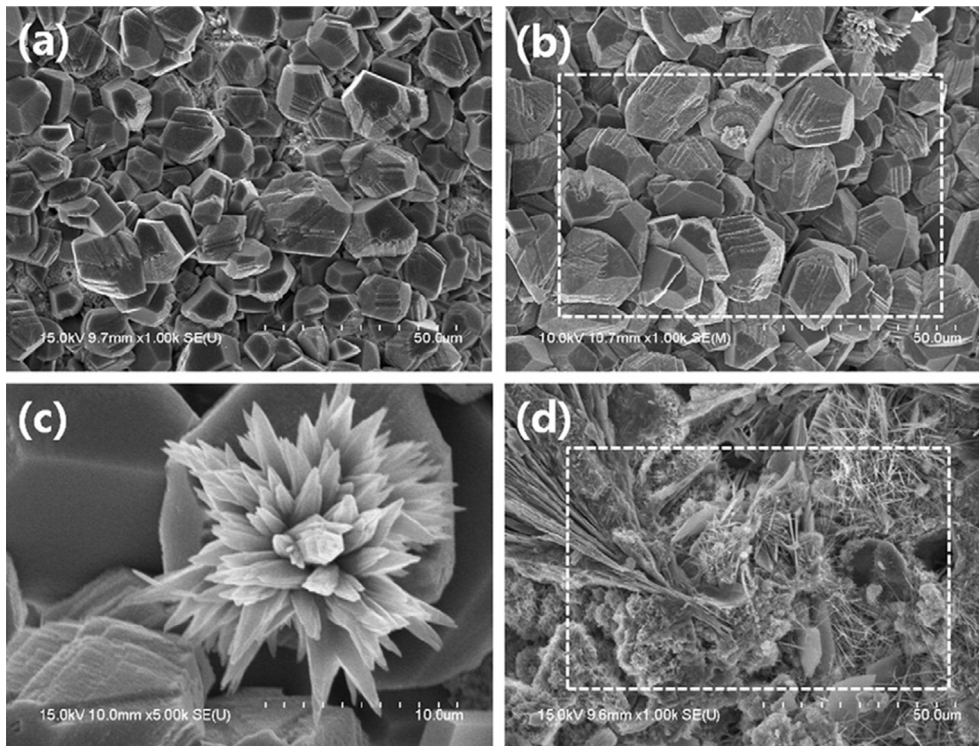

Fig. 12. Multi-method instrumental analytics approach using p-XRD and NMR spectroscopy to clarify C-S-H and C-A-S-H formation when using soluble silica species as self-healing promoter [73].



**Fig. 13.** Polymorphs of calcium carbonate formed in self-sealed cracks upon carbonation reactions imposed on well cementing composite containing Ca-doped mesoporous silica as self-healing agent [95].

- the imaging technique SEM or ESEM to optically identify the morphology, with
- overlaying EDX mapping for elemental analysis, and
- some further qualitative and quantitative but not spatially resolving method such as p-XRD, TGA/DSC, or IR

for routine analysis to yield sufficiently detailed information as the basis for primary chemical-mechanistic interpretation. More sophisticated instrumental analytical methods are, however, required for in-depth characterisation of self-healing products and to elucidate the underlying chemical reactions.

It is worth remarking that chemical and mineralogical characterisation of the self-healing products to understand self-healing mechanisms can only be meaningful if the constituents employed to promote self-healing, including those intentionally synthesised to the purpose, had been previously analysed in detail. As a matter of fact, the literature survey has revealed that calcium carbonate, mostly in the form of calcite, is the predominant self-healing material if no special promoters are used, irrespective of whether the matrix is based on Normal Portland Cement (NPC) as the sole binder or is blended with Supplementary Cementitious Materials (SCM). Besides, the hydration of un-hydrated NPC phases [146], especially  $C_3S$  and  $C_2S$ , was also confirmed as a cause of the healing especially for young concretes, as well as in mortars with Ground Granulated Blast Furnace Slag (GGBS), artificially cracked at ages younger than 28 days. This was supported by the observed pronounced formation of calcium silicate hydrate (C-S-H) phases, which had lower Ca/Si ratio than the surrounding matrix [124]. The same mechanism of delayed C-S-H formation was found to take place in high-volume fly ash strain-hardening cement-based composites (SHCC), which were mechanically cracked, at rather young ages of up to 28 days only. In such materials, portlandite was available to be consumed to a significant extent and to produce reactions only at later ages [153].

Where self-healing mineral promoters were intentionally introduced, instrumented analytics disclosed the respective reaction mechanisms and self-healing products (Fig. 11). For instance, silicate-based self-healing additives and admixtures, respectively, expectedly react primarily with portlandite forming new C-S-H phases. However, it was shown that there is a distinct potential of reaction with calcium aluminate species forming calcium aluminate/silicate hydrate (C-A-S-H) phases [3,73] (Fig. 12) or even increasing the amount of ettringite [84]. Upon intended carbonation of a well cementing composite enriched with Ca-doped mesoporous silica species as the self-healing promoter, polymorphs of calcium carbonate were detected in self-sealed cracks (Fig. 13). Self-healing approaches using bacteria unambiguously disclosed that the biologically intended excretion of calcium carbonate, mainly in the form of calcite, in fact was the decisive mechanism, e.g. [38,39,151,165,177,192]. Further details of chemical and mineralogical self-healing strategies and efficiencies can be found in [26].

In this respect it is furthermore worth remarking that, besides distinct chemical-mineralogical characterisation of any self-healing product, also characterisation of the “bond strength” between self-healing products and crack flanks, is also required as a basis for mechanical interpretation and modelling [77].

So far in the literature only “indications” or “claims” that the intrinsic mechanical properties of the respective self-healing products determine the mechanical properties of the self-healed body (i.e. with calcite lower than with “postulated” or “real”, i.e. proven, C-S-H being the major self-healing product species). Gilabert et al. [55] performed an experimental and numerical study to analyse the crack filling process in encapsulation-based self-healing concrete. The amount of healing agent released in the crack is visualized using micro Computed Tomography scanning. Tensile mechanical tests were performed to evaluate the strength contribution of the cured healing agent. A computational fluid dynamics

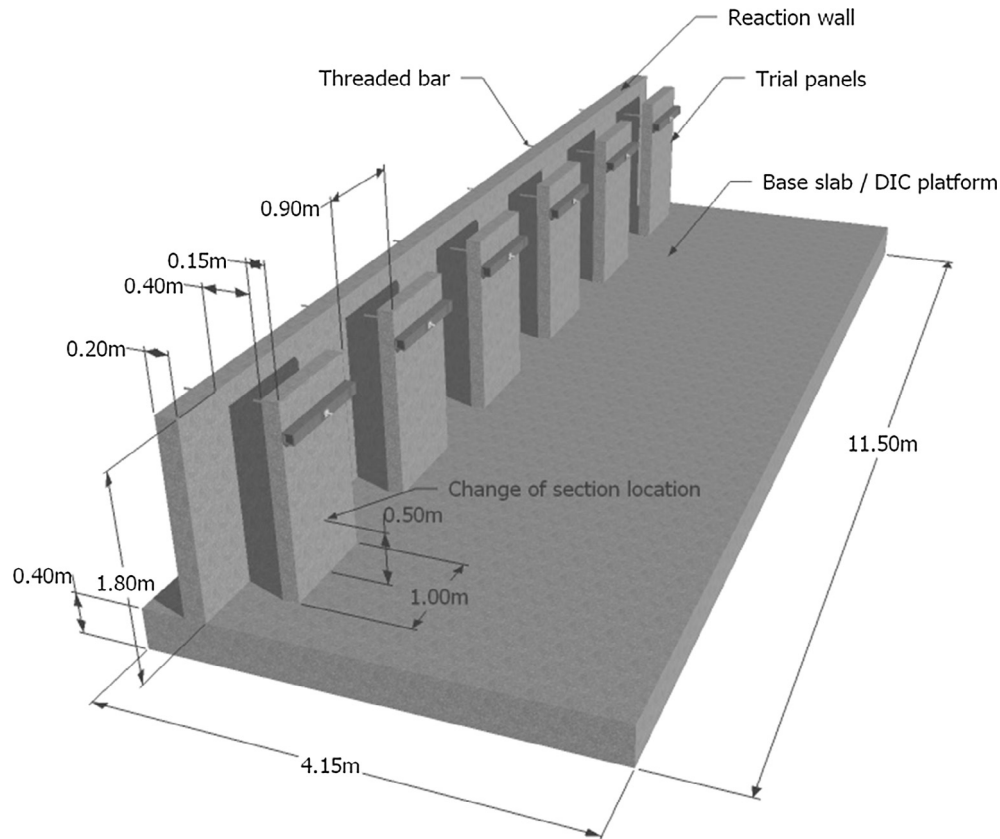

Fig. 14. Layout of test panels [167].

model was developed to understand how the healing agent spreads in the crack as a function of the crack width.

## 5. Monitored case studies

A set of site trials using a range of self-healing technologies were conducted by a joint team of researchers from Cardiff, Cambridge and Bath universities [166,167]. The trials were undertaken on a UK highways project and were facilitated by the main contractor Costain Group Plc. The trials comprised a number of concrete wall panels, each of which contained different self-healing materials/systems. These included; (i) microcapsules containing sodium silicate solution; (ii) bacteria-infused perlite and nutrient-infused perlite; (iii) shape memory polymer tendons and; (iv) embedded vascular networks for the delivery of a healing agent (sodium silicate).

The layout of the cantilever wall-panels, illustrated in Fig. 14.

It consisted of 6 test panels, which were loaded in flexure by the application of a normal horizontal force near the upper surface of the wall. The load was applied via tensioned bars, which were jacked against a reaction wall. The reinforced concrete cantilever wall panels were cast, left to cure for a period of approximately 35 days and then subjected to a series of loading cycles. Some panels were first loaded such that a horizontal crack formed up to a 0.3 mm opening. The panels were then unloaded, allowed for a self-healing curing period of 24 days and subsequently reloaded to assess the strength and stiffness regain. Other panels were left in stressed condition during the self-healing curing period such that the 0.3 mm cracks formed during the first loading cycle remained open during the self-healing curing period. The walls were monitored with displacement transducers, crack mouth opening gauges and a Digital Image Correlation (DIC) system.

The results of all panels that contained a self-healing component showed some degree of healing but in most cases the healing ratio was limited to a few percentage. One of the main benefits of the work was to show how laboratory scale self-healing techniques could be scaled up for real site applications.

## 6. Conclusions

In this paper experimental methods for characterizing the crack self-sealing and –healing capacity of cement based materials have been reviewed, together with the techniques for the analysis of the nature of self-healing products. A range of techniques to evaluate the effectiveness of self-healing and self-sealing technology, including preliminary controlled damage (pre-cracking) methods have been presented. Whenever possible, the correlation between crack sealing and healing recovery of the material physical and/or mechanical properties, as garnered through different experimental methodologies, have been highlighted, with the aim of paving the way to standardized approaches, for both testing and interpretation of the results. The main experimental artefacts that may affect the experimental results have been also pointed out.

From the performed literature review, the experimental characterization the self-healing capacity under sustained loads and through-crack stress states has been highlighted as a research need of the utmost importance which requires to be urgently tackled in order to provide a sound basis for incorporation of self-healing concepts and outcomes into predictive models and durability based design approaches.

The chemical and mineralogical characterisation of the self-sealing products is important to understand the mechanisms behind self-healing. A more profound knowledge of these mechanism will be required as a sound basis for modelling engineering

aspects, as well as to strengthen and broaden the experimental results. The characterisation of the “bond strength” between self-healing minerals or petrochemical polymers or crack flanks is furthermore required for a profound basis for mechanical interpretation and modelling. This is needed also in the sight of assessing, in a design-wise perspective, if and to what extent the intrinsic mechanical properties of the self-healing products determine the mechanical properties of the self-healed structural elements.

## Acknowledgements

The authors acknowledge the support from EU COST Action CA 15202 “SARCOS” (<http://www.sarcos.eng.cam.ac.uk>). E. Cuenca and L. Ferrara acknowledge the financial support of the PoliMi International Fellowships 2015 (PIF). T. Van Mullem and N. De Belie acknowledge the grant (17SCIP-B103706-03) from the Construction Technology Research Program funded by Ministry of Land, Infrastructure and Transport of Korean Government.

## References

- [1] V. Achal, A. Mukerjee, S. Reddy, Biogenic treatment improves the durability and remediates the cracks of concrete structures, *Constr. Build. Mater.* 48 (2013) 1–5, <https://doi.org/10.1016/j.conbuildmat.2013.06.061>.
- [2] D.G. Aggelis, T. Shiotani, D. Polyzos, Characterization of surface crack depth and repair evaluation using Rayleigh waves, *Cem. Concr. Compos.* 31 (2009) 77–83, <https://doi.org/10.1016/j.cemconcomp.2008.09.008>.
- [3] T.H. Ahn, T. Kishi, Crack self-healing behavior of cementitious composites incorporating various mineral admixtures, *J. Adv. Concr. Technol.* 8 (2) (2010) 171–186, <https://doi.org/10.3151/jact.8.171>.
- [4] E. Ahn, H. Kim, S.-H. Sim, S.W. Shin, M. Shin, Principles and applications of ultrasonic-based nondestructive methods for self-healing in cementitious materials, *Materials* 10 (2017) 278, <https://doi.org/10.3390/ma10030278>.
- [5] M. Ait Ouarabi, P. Antonaci, F. Boubenider, A.S. Gliozzi, M. Scalerandi, Ultrasonic monitoring of the interaction between cement matrix and alkaline silicate solution in self-healing systems, *Materials* 10 (1) (2017) 46, <https://doi.org/10.3390/ma10010046>.
- [6] A. Akhavan, F. Rajabipour, Evaluating ion diffusivity of cracked cement paste using electrical impedance spectroscopy, *Mater. Struct.* 46 (2013) 697–708, [10.1617/s11527-012-9927-x](https://doi.org/10.1617/s11527-012-9927-x).
- [7] C.M. Aldea, S.P. Shah, A. Karr, Permeability of cracked concrete, *Mater. Struct.* 32 (1999) 370–376, <https://doi.org/10.1007/BF02479629>.
- [8] C.M. Aldea, W.J. Song, J.S. Popovics, S.P. ad Shah, Extent of healing of cracked normal strength concrete, *ASCE J. Mater. Civil Eng.* 12 (1) (2000) 92–96, [https://doi.org/10.1061/\(ASCE\)0899-1561\(2000\)12:1\(92\)](https://doi.org/10.1061/(ASCE)0899-1561(2000)12:1(92)).
- [9] R. Alghamri, A. Kanellopoulos, Al-Tabbaa, Impregnation and encapsulation of lightweight aggregates for self-healing concrete, *Constr. Build. Mater.* 124 (2016) 910–921, [10.1016/j.conbuildmat.2016.07.143](https://doi.org/10.1016/j.conbuildmat.2016.07.143).
- [10] P.C. Aïtcin, *Binders for Durable and Sustainable Concrete*, Taylor and Francis, New York, 2008, pp. 347–348.
- [11] M. Araújo, S. Van Vlierberghe, J. Feiteira, G.-J. Graulus, K. Van Tittelboom, J.C. Martins, P. Dubrue, N. De Belie, Cross-linkable polyethers as healing/sealing agents for self-healing of cementitious materials, *Mater. Des.* 98 (2016) 215–222, <https://doi.org/10.1016/j.matdes.2016.03.005>.
- [12] ASTM C597, Standard Test Method for Pulse Velocity through Concrete, *ASTM American Society for testing and Materials International*, 2009.
- [13] S.S. Bang, K.J. Galinat, V. Ramakrishnan, Calcite precipitation induced by polyurethane-immobilized *Bacillus pasteurii*, *Enzyme Microb. Technol.* 28 (2001) 404–409, [https://doi.org/10.1016/S0141-0229\(00\)00348-3](https://doi.org/10.1016/S0141-0229(00)00348-3).
- [14] J. Becker, L.J. Jacobs, J. Qu, Characterization of cement-based materials using diffuse ultrasound, *ASCE J. Eng. Mech.* 129 (12) (2003) 1478–1484, [https://doi.org/10.1061/\(ASCE\)0733-9399\(2003\)129:12\(1478\)](https://doi.org/10.1061/(ASCE)0733-9399(2003)129:12(1478)).
- [15] R.P. Borg, E. Cuenca, E.M. Gastaldo Brac, L. Ferrara, Crack sealing capacity in chloride rich environments of mortars containing different cement substitutes and crystalline admixtures, *J. Sustainable Cement Based Mater.* (2017), <https://doi.org/10.1080/21650373.2017.1411297>.
- [16] A.M. Brandt, *Cement-Based Composites. Materials, Mechanical Properties and Performance*, second ed., Taylor and Francis, New York, 2017, p. 535.
- [17] F. Bravo da Silva, N. De Belie, N. Boon, W. Verstraete, Production of non-axenic ureolytic spores for self-healing concrete applications, *Constr. Build. Mater.* 93 (2015) 1034–1041, <https://doi.org/10.1016/j.conbuildmat.2015.05.049>.
- [18] Z.B. Bundur, A. Amiri, Y.C. Ersan, N. Boon, N. De Belie, Impact of air entraining admixtures on biogenic calcium carbonate precipitation and bacterial viability, *Cem. Concr. Res.* 98 (2017) 44–49, <https://doi.org/10.1016/j.cemconres.2017.04.005>.
- [19] A.I. Carpinteri, G. Lacidogna, F. Accornero, A.C. Mpataskas, T.E. Matinks, D.G. Aggelis, Influence of damage on the acoustic emission parameters, *Cem. Concr. Compos.* 44 (2013) 9–16, <https://doi.org/10.1016/j.cemconcomp.2013.08.001>.
- [20] H. Chen, C. Qian, H. Huang, Self-healing cementitious materials based on bacteria and nutrients immobilized respectively, *Constr. Build. Mater.* 126 (2016) 297–303, <https://doi.org/10.1016/j.conbuildmat.2016.09.023>.
- [21] H.N. Chen, R.K.L. Su, Study on fracture behaviors of concrete using electronic speckle pattern interferometry and finite element method, in *Proceedings of International Conference on Computational & Experimental Engineering and Sciences (ICCES'10)*, Las Vegas, USA, 91–101, (2010).
- [22] Z. Cohen, A. Peled, Controlled telescopic reinforcement system of fabric-cement composites – durability concerns, *Cement Concr. Res. J.* 40 (2010) 1495–1506, <https://doi.org/10.1016/j.cemconres.2010.06.003>.
- [23] O. Çopuroglu, E. Schlangen, T. Nishiwaki, K. Van Tittelboom, D. Snoeck, N. De Belie, M. de Rooij, Experimental techniques used to verify healing, *Self-Healing Phenomena in Cement-Based Materials. State-of-the-Art Report of RILEM Technical Committee 221-SHC*, Springer, 2013.
- [24] E. Cuenca, L. Ferrara, Repeatability of self-healing in fiber reinforced concretes with and without crystalline admixtures: preliminary results, in C.M. Aldea and M. Ekenel, eds., *Reduction of Crack Width with Fiber*, ACI Special Publication 319, 11.1–11.18. ISBN-13: 978-1-945487-68-2 (2017).
- [25] E. Cuenca, A. Tejedor, L. Ferrara, A methodology to assess crack sealing effectiveness of crystalline admixtures under repeated cracking-healing cycles, *Constr. Build. Mater.* (2018) (Submitted for publication).
- [26] N. De Belie, E. Gruyaert, A. Al-Tabbaa, P. Antonaci, C. Baera, D. Bajäre, A. Darquennes, R. Davies, L. Ferrara, A. Jefferson, C. Litina, B. Miljevic, A. Otlewska, J. Ranogajec, M. Roig, K. Paine, P. Ludowski, P. Serna, J.M. Tulliani, S. Vucetic, J. Wang, H. Jonkers, A review on self-healing concrete for damage management of structures, *Materials Interface Sci.* (2018).
- [27] C. De Nardi, A. Cecchi, L. Ferrara, A. Benedetti, D. Cristofori, Effect of age and level of damage on the autogenous healing of lime mortars, *Compos.-Part B: Eng.* (2017) 144–157, <https://doi.org/10.1016/j.compositesb.2017.05.041>.
- [28] C. De Nardi, S. Bullo, L. Ferrara, L. Ronchin, A. Vavasori, Effectiveness of crystalline admixtures and lime/cement microcapsules in engineered self-healing capacity of lime mortars, *Mater. Struct.* (2017). [10.1617/s11527-017-1053-3](https://doi.org/10.1617/s11527-017-1053-3).
- [29] M.R. De Rooij, E. Schlangen, Self-healing phenomena in cement-based materials, *State-of-the-Art Report of RILEM Technical Committee 221-SHC*, 2011.
- [30] M.R. De Rooij, K. Van Tittelboom, N. De Belie, E. Schlangen (Eds.), *Self-Healing Phenomena in Cement-based materials. State-of-the-Art Report of RILEM Technical Committee 221-SHC*, Springer, 2013, p. 266. ISBN: 978-94-007-6623-5 (Print) 978-94-007-6624-2 (Online).
- [31] S. Diamond, Mercury porosimetry – An inappropriate method for the measurement of pore size distributions in cement-based materials, *Cem. Concr. Res.* 30 (10) (2000) 1517–1525, [https://doi.org/10.1016/S0008-8846\(00\)00370-7](https://doi.org/10.1016/S0008-8846(00)00370-7).
- [32] A. Djerbi, S. Bonnet, A. Khelidj, V. Baroghel-Bouny, Influence of traversing crack on chloride diffusion into concrete, *Cem. Concr. Res.* 38 (2008) 877–883, <https://doi.org/10.1016/j.cemconres.2007.10.007>.
- [33] Y. Ding, Z. Chen, Z. Han, Y. Zhang, F. Pacheco-Torgal, Nano-carbon black and carbon fiber as conductive materials for the diagnosing of the damage of concrete beam, *Constr. Build. Mater.* 43 (2013) 233–241, <https://doi.org/10.1016/j.conbuildmat.2013.02.010>.
- [34] M. di Prisco, L. Ferrara, M.G.L. Lamperti, Double Edge Wedge Splitting (DEWS): an indirect tension test to identify post-cracking behaviour of fibre reinforced cementitious composites, *Mater. Struct.* 46 (11) (2013) 1893–1918, [10.1617/s11527-013-0028-2](https://doi.org/10.1617/s11527-013-0028-2).
- [35] D. Dvorkin, A. Peled, Effect of reinforcement with carbon fabrics impregnated with nanoparticles on the tensile behavior of cement-based composites, *Cem. Concr. Res.* 85 (2016) 28–38, <https://doi.org/10.1016/j.cemconres.2016.03.008>.
- [36] D. Dvorkin, A. Pourasee, A. Peled, J. Weiss, Influences of bundle coating on tensile behavior, bonding, cracking and fluid transport of fabric cement-based composites, *Cement Concr. Compos. J.* 42 (2013) 9–19, <https://doi.org/10.1016/j.cemconcomp.2013.05.005>.
- [37] EN 12504-4. Testing Concrete in Structures. Part 4. Determination of Ultrasonic Pulse Velocity. CEN European Committee for Standardization 2004.
- [38] Y.Ç. Ersan, E. Gruyaert, G. Louis, C. Lora, N. De Belie, N. Boon, Self-protected nitrate reducing culture for intrinsic repair of concrete cracks, *Front. Microbiol.* 6 (2015), <https://doi.org/10.3389/fmicb.2015.01228>. article ID 1228.
- [39] Y.Ç. Erşan, E. Hernandez-Sanabria, N. Boon, N. De Belie, Enhanced crack closure performance of microbial mortar through nitrate reduction, *Cem. Concr. Compos.* 70 (2016) 159–170, <https://doi.org/10.1016/j.cemconcomp.2016.04.001>.
- [40] S. Fan, M. Li, X-ray computed microtomography of three-dimensional microcracks and self-healing in engineered cementitious composites, *Smart Mater. Struct.* 24 (2015), <https://doi.org/10.1088/0964-1726/24/1/01521>. article ID 15021 (14 pages).
- [41] J. Feiteira, E. Gruyaert, N. De Belie, Self-healing of moving cracks in concrete by means of encapsulated precursors, *Constr. Build. Mater.* 102 (2016) 671–678, <https://doi.org/10.1016/j.conbuildmat.2015.10.192>.
- [42] J. Feiteira, E. Tsangouri, E. Gruyaert, C. Lora, G. Louis, N. De Belie, Monitoring crack movement in polymer-based self-healing concrete through digital image correlation, acoustic emission analysis and SEM in-situ loading, *Mater. Des.* 115 (2017) 238–246, <https://doi.org/10.1016/j.matdes.2016.11.050>.

- [43] L. Ferrara, V. Krelani, M. Carsana, A fracture testing based approach to assess crack healing of concrete with and without crystalline admixtures, *Constr. Build. Mater.* 68 (2014) 515–531, <https://doi.org/10.1016/j.conbuildmat.2014.07.008>.
- [44] L. Ferrara, I. Albertini, R. Gettu, V. Krelani, S. Moscato, F. Pirritano, S. Theeda, Self-healing of cement based materials engineered through crystalline admixtures: experimental results form a multinational university network, *ACI Special Publication 305*, 2015. 13.1–13.10. ISBN-13: 978-1-942727-44-6.
- [45] L. Ferrara, S.R. Ferreira, V. Krelani, M. Della Torre, F. Silva, R. Toledo, Natural fibers as promoters of autogenous healing in HPRCCs: Results from on-going Brazil-Italy cooperation, *ACI Special Publication*, 2015. 305, 11.1–11.10.
- [46] L. Ferrara, V. Krelani, F. Moretti, On the use of crystalline admixtures as promoters of self-healing in cement based construction materials, *Smart Mater. Struct.* 25 (8) (2016), <https://doi.org/10.1088/0964-1726/25/8/084002>.
- [47] L. Ferrara, V. Krelani, F. Moretti, Autogenous healing on the recovery of mechanical performance of High Performance Fibre Reinforced Cementitious Composites (HPFRCCs): part 2 - correlation between healing of mechanical performance and crack sealing, *Cem. Concr. Compos.* 73 (2016) 299–315, <https://doi.org/10.1016/j.cemconcomp.2016.08.003>.
- [48] L. Ferrara, V. Krelani, F. Moretti, M. Roig-Flores, P. Serna, Effects of autogenous healing on the recovery of mechanical performance of High Performance Fibre Reinforced Cementitious Composites (HPFRCCs): part 1, *Cem. Concr. Compos.* 83 (2017) 76–100, <https://doi.org/10.1016/j.cemconcomp.2017.07.010>.
- [49] L. Ferrara, S.R. Ferreira, V. Krelani, Nunes da Cunha, T. Moreira, F. De Andrade Silva, R.D. Toledo Filho, Self-healing capacity of hybrid sisal-steel fiber reinforced cementitious composites and comparison with steel only HPFRCCs, *Constr. Build. Mater.* (2017).
- [50] L. Ferrara, E. Cuenca, Effects of self-healing promoted by crystalline admixture on the concrete resistance to chloride penetration. Accepted for publication to DSCS 2018, 2nd International Workshop on Durability and Sustainability of Concrete Structures, Moscow, Russia, 6–7 June 2018 (2018).
- [51] A. Formia, S. Irico, F. Bertola, F. Canonico, P. Antonaci, N.M. Pugno, J.M. Tulliani, Experimental analysis of self-healing cement-based materials incorporating extruded cementitious hollow tubes, *J. Intelligent Mater. Syst. Struct.* 27 (2016) 2633–2652, <https://doi.org/10.1177/1045389X16635847>.
- [52] D. Fukuda, Y. Nara, D. Hayashi, H. Ogawa, K. Kaneko, Influence of fracture width on sealability in high-strength and ultra-low-permeability concrete in seawater, *Materials* 6 (2013) 2578–2594, <https://doi.org/10.3390/ma6072578>.
- [53] G. Ganendra, J. Wang, J.A. Ramos, H. Derluyn, H. Rahier, V. Cnudde, A. Ho, N. Boon, Biogenic concrete protection driven by the formate oxidation by *Mehtylocystis parvus* OBPP, *Front. Microbiol.* 6 (2015), <https://doi.org/10.3389/fmicb.2015.00786>, article ID 786.
- [54] P. Giannaros, A. Kanellopoulos, A. Al-Tabbaa, Sealing of cracks in cement using microencapsulated sodium silicate, *Smart Mater. Struct.* 25 (2016) 1–12, <https://doi.org/10.1088/0964-1726/25/8/084005>.
- [55] F.A. Gilabert, K. Van Tittelboom, J. Van Stappen, V. Cnudde, N. De Belie, W. Van Paeppegem, Integral procedure to assess crack filling and mechanical contribution of polymer-based healing agent in encapsulation-based self-healing concrete, *Cem. Concr. Compos.* 77 (2017) 68–80, <https://doi.org/10.1016/j.cemconcomp.2016.12.001>.
- [56] A.S. Gliozzi, M. Scalerandi, P. Antonaci, G. Angliani, L. Salini, Correlation of elastic and mechanical properties of consolidated granular media during microstructure evolution induced by damage and repair, *Phys. Rev. Mater.* (2017), in press.
- [57] Y. Goldfeld, O. Rabinovitch, B. Fishbain, T. Quadflieg, T. Gries, Sensory carbon fiber based textile reinforced concrete for smart structures, *J. Intel. Mater. Syst. Struct.* 27 (4) (2016) 469–489, <https://doi.org/10.1177/1045389X15571385>.
- [58] Y. Goldfeld, O. Rabinovitch, T. Quadflieg, T. Gries, (2015). Integrated monitoring of TRC using carbon fibers. Ferro-11, 11th International Symposium on Ferrocement and 3rd International Conference on Textile Reinforced Concrete, edited by Wolfgang Bramshuber, Published by RILEM publications S.A.R.L, Aachen, Germany, 327–334.
- [59] Y. Goldfeld, S. Ben-Aarosh, O. Rabinovitch, T. Quadflieg, T. Gries, Integrated self-monitoring of carbon based textile reinforced concrete beams under repeated loading, *Carbon* 98 (2016) 238–249, <https://doi.org/10.1016/j.carbon.2015.10.056>.
- [60] B. Goszczyńska, G. Świt, W. Trąmpczyński, Analysis of the microcracking process with the Acoustic Emission method with respect to the service life of reinforced concrete structures with the example of the RC beams, *Bull. Polish Acad. Sci. Tech. Sci.* 63 (1) (2015) 55–63, <https://doi.org/10.1515/bpasts-2015-0007>.
- [62] S. Granger, A. Loukili, G. Cabot-Pijaudier, G. Chanvillard, Experimental characterization of the self-healing of cracks in an ultra high performance cementitious material: Mechanical tests and acoustic emission analysis, *Cem. Concr. Res.* 37 (4) (2007) 519–527, <https://doi.org/10.1016/j.cemconres.2006.12.005>.
- [63] E. Gruyaert, D. Debbaut, D. Snoeck, P. Díaz, A. Arizo, E. Tziviloglou, E. Schlangen, N. De Belie, Self-healing mortar with pH-sensitive superabsorbent polymers: testing of the sealing efficiency by water flow tests, *Smart Materials and Structures* 25 (084007) (2016) 11, <https://doi.org/10.1088/0964-1726/25/8/084007>.
- [64] E. Gruyaert, J. Feiteira, N. De Belie, F. Malm, M. Nahm, C.U. Grosse, E. Tziviloglou, E. Schlangen, E. Tsangouri, (2016). Non-destructive testing techniques to evaluate the healing efficiency of self-healing concrete at lab-scale, Keynote paper, D. Aggelis et al. (Eds.), *Emerging Technologies in Non-Destructive Testing VI*, Taylor & Francis Group, London, pp. 227–234 (ISBN 978-1-138-02884-5). Post-proceedings of ETNDT6 - 6th International Conference on Emerging Technologies in Non-destructive Testing, Brussels, 2015.
- [65] R.A. Guyer, J.A. TenCate, P.A. Johnson, Hysteresis and the dynamic elasticity of consolidated granular materials, *Phys. Rev. Lett.* 82 (1999) 3280–3283, <https://doi.org/10.1103/PhysRevLett.82.3280>.
- [66] N. Hearn, Self-sealing, autogenous healing and continued hydration: what is the difference?, *Mater Struct.* 31 (8) (1998) 563–567, <https://doi.org/10.1007/BF02481539>.
- [67] B. Hilloulin, J.-B. Legland, E. Lys, O. Abraham, A. Loukili, F. Grondin, O. Durand, V. Tourmat, Monitoring of autogenous crack healing in cementitious materials by the nonlinear modulation of ultrasonic coda waves, 3D microscopy and X-ray microtomography, *Constr. Build. Mater.* 123 (2016) 143–152, <https://doi.org/10.1016/j.conbuildmat.2016.06.138>.
- [68] D. Homma, H. Mihashi, T. Nishiwaki, Self-healing capability of fibre reinforced cementitious composites, *J. Adv. Concr. Technol.* 7 (2) (2009) 217–228, <https://doi.org/10.3151/jact.7.217>.
- [69] H. Huang, G. Ye, Application of sodium silicate solution as self-healing agent in cementitious materials, Proceedings International RILEM conference on advances in construction materials through science and engineering, (2001) 530–536.
- [70] H. Huang, G. Ye, L. Pel, New insights into autogenous self-healing in cement paste based on nuclear magnetic resonance (NMR) tests, *Mater. Struct.* 49 (7) (2016) 2509–2524, <https://doi.org/10.1617/s11527-015-0664-9>.
- [71] S. Igarashi, M. Kawamura, A. Watanabe, Analysis of cement pastes and mortars by a combination of backscatter-based SEM image analysis and calculations based on the Powers model, *Cem. Concr. Compos.* 26 (8) (2004) 977–985, <https://doi.org/10.1016/j.cemconcomp.2004.02.031>.
- [72] C.W. In, R. Brett Holland, J.Y. Kim, K.E. Kurtis, L.F. Kahn, L.J. Jacobs, Monitoring and evaluation of self-healing in concrete using diffuse ultrasound, *NDT&E International* 57 (2013) 36–44, <https://doi.org/10.1016/j.ndteint.2013.03.005>.
- [73] S. Irico, A.G. Bovio, G. Paul, E. Boccaleri, D. Gastaldi, L. Marchese, L. Buzzi, F. Canonico, A solid-state NMR and X-ray powder diffraction investigation of the binding mechanism for self-healing cementitious materials design: The assessment of the reactivity of sodium silicate based systems, *Cem. Concr. Compos.* 76 (2017) 57–63, <https://doi.org/10.1016/j.cemconcomp.2016.11.000>.
- [74] M. Ismail, A. Toumi, R. Francois, R. Gagne, Effect of crack opening on the local diffusion of chloride in cracked mortar samples, *Cem. Concr. Res.* 38 (2008) 1106–1111, <https://doi.org/10.1016/j.cemconres.2008.03.009>.
- [75] S. Jacobsen, J. Marchand, H. Homain, SEM observations of the microstructure of frost deteriorated and self-healed concretes, *Cem. Concr. Res.* 25 (8) (1995) 1781–1790, [https://doi.org/10.1016/0008-8846\(95\)00174-3](https://doi.org/10.1016/0008-8846(95)00174-3).
- [76] D. Jaroentranapirom, R. Sahamitmongkol, Self-Crack Closing Ability of Mortar with Different Additives, *J. Metals, Mater. Miner.* 21 (1) (2011) 9–17.
- [77] A.D. Jefferson, E. Javierre, B. Freeman, A. Zaoui, E. Keoners, L. Ferrara, Research progress on numerical models for self-healing cementitious materials, *Mater. Interface Sci.* (2018).
- [78] Z. Jiang, W. Li, Z. Yuan, Z. Yang, Self-healing of cracks in concrete with various crystalline mineral additives in underground environment, *J. Wuhan Univ. Technol. - Mater. Sci. Ed.* 29 (5) (2014) 938–944, <https://doi.org/10.1007/s11595-014-1024-2>.
- [79] H. Jonkers, Bacteria-based self-healing concrete, *Heron* 56 (1/2) (2011) 1–12.
- [80] H. Jonkers, A. Thijssen, G. Muyzer, O. Copuroglu, E. Schlangen, Application of bacteria as self-healing agent for the development of sustainable concrete, *Ecol. Eng.* 36 (2) (2010) 230–235, <https://doi.org/10.1016/j.ecoleng.2008.12.036>.
- [81] D. Jóźwiak-Niedźwiedzka, Microscopic observations of self-healing products in calcereous fly ash mortars, *Microsc. Res. Tech.* 78 (2015) 22–29, <https://doi.org/10.1002/jemt.22440>.
- [82] L. Kan, H. Shi, A. Sakulich, V. Li, Self-healing characterization of engineered cementitious composite materials, *ACI Mater. J.* 107 (6) (2010) 617–624, <https://doi.org/10.14359/51664049>.
- [83] A. Kanellopoulos, T.S. Qureshi, A. Al-Tabbaa, Glass encapsulated minerals for self-healing in cement based composites, *Constr. Build. Mater.* 98 (2015) 780–791, <https://doi.org/10.1016/j.conbuildmat.2015.08.127>.
- [84] A. Kanellopoulos, P. Giannaros, A. Al-Tabbaa, The effect of varying volume fraction of microcapsules on fresh, mechanical and self-healing properties of mortars, *Constr. Build. Mater.* 122 (2016) 577–593, <https://doi.org/10.1016/j.conbuildmat.2016.06.119>.
- [85] G. Karaiskos, E. Tsangouri, D. Aggelis, K. Van Tittelboom, N. De Belie, D. Van Hemelrijck, Performance monitoring of large-scale autonomously healed concrete beams under four-point bending through multiple non-destructive testing methods, *Smart Mater. Struct.* 25 (2016) 16, <https://doi.org/10.1088/0964-1726/25/5/055003>.
- [86] W. Khaliq, M.B. Ehsan, Crack healing in concrete using various bio influenced self-healing techniques, *Constr. Build. Mater.* 102 (2016) 349–357, <https://doi.org/10.1016/j.conbuildmat.2015.11.006>.
- [87] J. Kim, E. Schlangen, Self-healing in ECC stimulated by SAP under flexural cyclic load. 3rd International Conference on Self-Healing Materials. Bath (2011).

- [88] D. Kim, S. Kang, T. Ahn, Mechanical characterization of high-performance steel-fiber reinforced cement composites with self-healing effect, *Materials* 7 (1) (2014) 508–526, <https://doi.org/10.3390/ma7010508>.
- [89] G. Kim, J.-Y. Kim, K.E. Kurtis, L.J. Jacobs, Drying shrinkage in concrete assessed by nonlinear ultrasound, *Cem. Concr. Res.* 92 (2017) 16–20, <https://doi.org/10.1016/j.cemconres.2016.11.010>.
- [90] K. Komloš et al., Ultrasonic pulse velocity test of concrete properties as specified in various standards, *Cem. Concr. Compos.* 18 (1996) 357–364, [https://doi.org/10.1016/0958-9465\(96\)00026-1](https://doi.org/10.1016/0958-9465(96)00026-1).
- [91] A. Konin, R. François, G. Arliguie, Penetration of chlorides in relation to the microcracking state into reinforced ordinary and high strength concrete, *Mater. Struct.* 31 (1998) 310–316, <https://doi.org/10.1007/BF02480672>.
- [92] K.R. Lauer, F.O. Slate, Autogenous healing of cement paste, *Proc. ACI* 52 (1956) 1083–1097.
- [93] Y.-S. Lee, J.-S. Ryou, Self healing behavior for crack closing of expansive agent via granulation/film coating method, *Constr. Build. Mater.* 71 (2014) 188–193, <https://doi.org/10.1016/j.conbuildmat.2014.08.045>.
- [94] H.X.D. Lee, H.S. Wong, N.R. Buenfeld, Self-sealing of cracks in concrete using superabsorbent polymers, *Cem. Concr. Res.* 79 (2016) 194–208, <https://doi.org/10.1016/j.cemconres.2015.09.008>.
- [95] S.-W. Lee, M. Jo, J.-W. Kim, T. Kim, Application of Ca-doped mesoporous silica to well-grouting cement for enhancement of self-healing capacity, *Mater. Des.* 89 (2016) 362–368, <https://doi.org/10.1016/j.matdes.2015.09.131>.
- [96] M.D. Lepech, V. Li, Water permeability of engineered cementitious composites, *Cem. Concr. Compos.* 31 (2009) 744–753, <https://doi.org/10.1016/j.cemconcomp.2009.07.002>.
- [97] V. Li, Y. Lim, Y. Chan, Feasibility of a passive smart self-healing cementitious composite, *Compos. B Eng.* 29 (1998) 819–827, [https://doi.org/10.1016/S1359-8368\(98\)00034-1](https://doi.org/10.1016/S1359-8368(98)00034-1).
- [98] M. Li, V. Li, Cracking and healing of engineered cementitious composites under chloride environment, *ACI Mater. J.* 108 (3) (2011) 333–340, <https://doi.org/10.14359/51682499>.
- [99] W. Li, Z. Jiang, Z. Yang, N. Zhao, W. Yuan, Self-healing efficiency of cementitious materials containing microcapsules filled with healing adhesive: Mechanical restoration and healing process monitored by water absorption, *PLoS One* 8 (11) (2013), <https://doi.org/10.1371/journal.pone.0081616>, article ID e81616.
- [100] W. Li, Z. Jiang, Z. Yang, Acoustic characterization of damage and healing of microencapsulation based self-healing cement pastes, *Cement Concr. Compos.* 84 (2017) 48–61, <https://doi.org/10.1016/j.cemconcomp.2017.08.013>.
- [101] S. Liu, Z.B. Bundur, J. Zhu, R.D. Ferron, Evaluation of self-healing of internal cracks in biomimetic mortar using coda wave interferometry, *Cem. Concr. Res.* 83 (2016) 70–78, [10.1016/j.cemconres.2016.01.006](https://doi.org/10.1016/j.cemconres.2016.01.006).
- [102] M.W. Loving, Autogenous healing of concrete, *Bulletin, American Concrete Pipe Association* 13 (1936) 3.
- [103] P. Lukowski, G. Adamczewski, Self-repairing of polymer-cement concrete, *Bull. Polish Acad. Sci. Tech. Sci.* 61 (1) (2013) 195–200, <https://doi.org/10.2478/bpasts-2013-0018>.
- [104] M. Luo, C.X. Qian, R.X. Li, Factors affecting crack repairing capacity of bacteria-based self-healing concrete, *Constr. Build. Mater.* 87 (2015) 1–7, <https://doi.org/10.1016/j.conbuildmat.2015.03.117>.
- [105] Z. Lv, D. Chen, Overview of recent work on self-healing in cementitious materials, *Materiales de Construcción* 64 (316) (2014) 12, <https://doi.org/10.3989/mc.2014.05313>.
- [106] H. Ma, S. Qian, Z. Zhang, Effect of self healing on water permeability and mechanical property of medium-early-strength engineered cementitious composites, *Constr. Build. Mater.* 68 (2014) 92–101, <https://doi.org/10.1016/j.conbuildmat.2014.05.065>.
- [107] M. Maes, K. Van Tittelboom, N. De Belie, The efficiency of self-healing cementitious materials by means of encapsulated polyurethane in chloride containing environments, *Constr. Build. Mater.* 71 (2014) 528–537, <https://doi.org/10.1016/j.conbuildmat.2014.08.053>.
- [108] M. Maes, D. Snoeck, N. De Belie, Chloride penetration in cracked mortar and the influence of autogenous crack healing, *Constr. Build. Mater.* 115 (2016) 114–124, <https://doi.org/10.1016/j.conbuildmat.2016.03.180>.
- [109] W.J. McCarter, G. Starrs, T.M. Chriss, P.F.G. Banfill, Activation and conduction in carbon fibre reinforced cement matrices, *J. Mater. Sci.* 42 (2007) 2200–2203, <https://doi.org/10.1007/s10853-007-1517-x>.
- [110] V. Mechtcherine, M. Lieboldt, Permeation of water and gases through cracked textile reinforced concrete, *Cem. Concr. Compos.* 33 (7) (2011) 725–734, <https://doi.org/10.1016/j.cemconcomp.2011.04.001>.
- [111] A. Mignon, D. Snoeck, D. Schaubroeck, N. Luickx, P. Dubruel, S. Van Vlierbergh, N. De Belie, pH-responsive superabsorbent polymers: A pathway to self-healing of mortar, *React. Funct. Polym.* 93 (2015) 68–76, <https://doi.org/10.1016/j.reactfunctpolym.2015.06.003>.
- [112] H. Mihashi, T. Nishiwaki, K. Miura, Y. Okuhara, (2008). Advanced monitoring sensor and self-repairing system for cracks in concrete structures. Proceedings, International RILEM Conference on Site Assessment of Concrete, Masonry and Timber Structures, Varenna, Lake Como, Italy, 401–409.
- [113] H. Mihashi, T. Nishiwaki, Development of engineered self-healing and self-repairing concrete – State-of-the-art report, *J. Adv. Concr. Technol.* 10 (2012) 170–184, <https://doi.org/10.3151/jact.10170>.
- [114] F. Moro, H. Böhni, Ink-bottle effect in mercury intrusion porosimetry of cement-based materials, *J. Colloid Interface Sci.* 246 (2002) 135–149, <https://doi.org/10.1006/jcis.2001.7962>.
- [115] E. Mostavi, S. Asadi, M.N. Hassan, M. Alansari, Evaluation of self-healing mechanisms in concrete with double-walled sodium silicate microcapsules, *ASCE J. Mater. Civil Eng.* 27 (12) (2015) 1–8, [https://doi.org/10.1061/\(ASCE\)MT.1943-5533.0001314](https://doi.org/10.1061/(ASCE)MT.1943-5533.0001314).
- [116] S. Mu, G. De Schutter, B. Ma, Non-steady state chloride diffusion in concrete with different crack densities, *Mater. Struct.* 46 (2013) 123–133, <https://doi.org/10.1617/s11527-012-9888-0>.
- [117] N.Z. Muhammad, A. Shafagha, A. Key Vanfar, M.Z. Abd Majid, S.K. Ghoshal, S. E. Mohammad Yasouj, A. Adekunle Ganiyu, M. Samadi Kouchaksaraei, H. Kamyab, M. Mahdi Taheri, M. Rezaazadeh Shirdar, R. Mc Caffer, Tests and methods of evaluating the self-healing efficiency of concrete: a review, *Constr. Build. Mater.* 112 (2016) 1123–1132, <https://doi.org/10.1016/j.conbuildmat.2016.03.17>.
- [118] J. Navarro-Gregori, E. Mezquida-Alcaraz, P. Serna-Ros, J. Echegaray-Oviedo, Experimental study on the steel-fibre contribution to concrete shear behaviour, *Constr. Build. Mater.* 112 (2016) 100–111, <https://doi.org/10.1016/j.conbuildmat.2016.02.157>.
- [119] T.G. Nijland, J.A. Larbi, R.P. Van Hees, B. Lubelli, M. de Rooij, (2007). Self healing phenomena in concretes and masonry mortars: a microscopic study. In: Proceedings of the First International Conference on Self-Healing Materials, 18–20 April 2007.
- [120] A. Neville, Autogenous healing—A concrete miracle, *Concr. Int.* 24 (2002) 76–82.
- [121] T. Nishiwaki, M. Koda, M. Yamada, H. Mihashi, T. Kikuta, Experimental Study on Self-Healing Capability of FRCC using different types of synthetic fibers, *J. Adv. Concr. Technol.* 10 (2012) 195–206, <https://doi.org/10.3151/jact.10.195>.
- [122] T. Nishiwaki, S. Kwon, D. Homma, M. Yamada, H. Mihashi, Self-healing capability of fiber-reinforced cementitious composites for recovery of watertightness and mechanical properties, *Materials* 7 (2014) 2141–2154, <https://doi.org/10.3390/ma7032141>.
- [123] T. Nishiwaki, H. Sasaki, S. Kwon, G. Igarashi, H. Mihashi, (2015). Experimental study on self-healing effect of FRCC with PVA fibers and additives against freeze/thaw cycles. Proceedings of ICSHM 2015.
- [124] K. Olivier, A. Darquennes, F. Benboudjema, R. Gagné, Early-age self-healing of cementitious materials containing ground granulated blast-furnace slag under water curing, *J. Adv. Concr. Technol.* 14 (2016) 717–727, <https://doi.org/10.3151/jact.14.717>.
- [125] E. Özbay, M. Şahmaran, H. Yücel, T. Erdem, M. Lachemi, V. Li, Effect of sustained flexural loading on Self-Healing of Engineered Cementitious Composites, *J. Adv. Concr. Technol.* 11 (2013) 167–179, <https://doi.org/10.3151/jact.11.167>.
- [126] E. Özbay, M. Şahmaran, M. Lachemi, H. Yücel, Self-healing of microcracks in high volume fly ash incorporated engineered cementitious composites, *ACI Mater. J.* 110 (2013) 33–44.
- [127] D. Palin, H.M. Jonkers, V. Wiktor, Autogenous healing of sea-water exposed mortar: Quantification through a simple and rapid permeability test, *Cem. Concr. Res.* 84 (2016) 1–7, <https://doi.org/10.1016/j.cemconres.2016.02.011>.
- [128] B. Pang, Z. Zhou, P. Hou, P. Du, L. Zhang, H. Xu, Autogenous and engineered healing mechanisms of carbonated steel slag aggregate in concrete, *Constr. Build. Mater.* 107 (2016) 191–202, <https://doi.org/10.1016/j.conbuildmat.2015.12.191>.
- [129] J. Parks, M. Edwards, P. Vikesland, A. Dudi, Effects of Bulk Water Chemistry on Autogenous Healing of Concrete, *ASCE J. Mater. Civil Eng.* 22 (5) (2010) 515–524, [https://doi.org/10.1061/\(ASCE\)MT.1943-5533.0000082](https://doi.org/10.1061/(ASCE)MT.1943-5533.0000082).
- [130] B. Pease, M. Geiker, H. Stang, J. Weiss, (2006). Photogrammetric assessment of flexure induced cracking of reinforced concrete beams under service loads. Proceedings 2nd International RILEM Symposium: Advances in Concrete Through Science and Engineering.
- [131] A. Peled, J.M. Torrents, T.O. Mason, S.P. Shah, E.J. Garboczi, Electrical impedance spectra to monitor damage during tensile loading of cement composites, *ACI Mater. J.* 98 (4) (2001) 313–322.
- [132] M.A. Pereira Gomes De Araujo, S. Van Vlierbergh, J.L. Garcia Feiteira, G.J. Graulius, K. Van Tittelboom, J. Martins, P. Dubruel, et al., Cross-linkable polyethers as healing/sealing agents for self-healing of cementitious materials, *Mater. Des.* 98 (2016) 215–222, <https://doi.org/10.1016/j.matdes.2016.03.005>.
- [133] G. Perez, J.J. Gaitero, E. Erkizia, I. Jimenez, A. Guerrero, Characterisation of cement pastes with innovative self-healing system based in epoxy-amine adhesive, *Cem. Concr. Compos.* 60 (2015) 55–64, <https://doi.org/10.1016/j.cemconcomp.2015.03.010>.
- [134] A. Pourasee, A. Peled, J. Weiss, Fluid transport in cracked fabric reinforced cement-based composites, *ASCE J. of Materials, Civ. Eng.* 23 (2011) 1277–1288, [https://doi.org/10.1061/\(ASCE\)MT.1943-5533.0000289](https://doi.org/10.1061/(ASCE)MT.1943-5533.0000289).
- [135] S. Qian, J. Zhou, M. De Rooij, E. Schlangen, G. Ye, K. Van Breugel, Self-healing behavior of strain hardening cementitious composites incorporating local waste materials, *Cem. Concr. Compos.* 31 (2009) 613–621, <https://doi.org/10.1016/j.cemconcomp.2009.03.003>.
- [136] S.X. Qian, J. Zhou, E. Schlangen, Influence of curing condition and precracking time on the self-healing behavior of Engineered Cementitious Composites, *Cem. Concr. Compos.* 32 (2010) 686–693, <https://doi.org/10.1016/j.cemconcomp.2010.07.015>.

- [137] T.S. Qureshi, A. Kanellopoulos, A. Al-Tabaa, Encapsulation of expansive powder minerals within a concentric glass capsule system for self-healing concrete, *Constr. Build. Mater.* 121 (2016) 629–643, <https://doi.org/10.1016/j.conbuildmat.2016.06.030>.
- [138] Z. Ranachowski, D. Józwiak-Niedzwiedzka, P. Ranachowski, F. Rejmund, M. Dabrowski, S. Kudela, T. Dvorak, Application of X-Ray microtomography and optical microscopy to determine the microstructure, *Arch. Metall. Mater.* 59 (4) (2014), <https://doi.org/10.2478/amm-2014-0245>.
- [139] G. Rodríguez, J.R. Casas, S. Villaba, Cracking assessment in concrete structures by distributed optical fiber, *Smart Mater. Struct.* 24 (3) (2015), <https://doi.org/10.1088/0964-1726/24/3/035005>.
- [140] M. Roig-Flores, S. Moscato, P. Serna, L. Ferrara, Self-healing capability of concrete with crystalline admixtures in different environments, *Constr. Build. Mater.* 86 (2015) 1–11, <https://doi.org/10.1016/j.conbuildmat.2015.03.091>.
- [141] M. Roig Flores, F. Pirritano, P. Serna Ros, L. Ferrara, Effect of crystalline admixtures on the self-healing capability of early-age concrete studied by means of permeability and crack closing tests, *Constr. Build. Mater.* 114 (2016) 447–457, <https://doi.org/10.1016/j.conbuildmat.2016.03.196>.
- [142] B.B. Sabir, S. Wild, M. O'Farrell, A water sorptivity test for mortar and concrete, *Mater. Struct.* 31 (8) (1998) 568–574, <https://doi.org/10.1007/BF02481540>.
- [143] M. Şahmaran, Effect of flexure induced transverse crack and self-healing on chloride diffusivity of reinforced mortar, *J. Mater. Sci.* 42 (2007) 9131, <https://doi.org/10.1007/s10853-007-1932-z>.
- [144] M. Şahmaran, M. Li, V. Li, Transport properties of engineered cementitious composites under chloride exposure, *ACI Mater. J.* 104 (6) (2007) 604–611.
- [145] M. Şahmaran, V. Li, Durability of mechanically loaded engineered cementitious composites under highly alkaline environments, *Cem. Concr. Compos.* 30 (2008) 72–81, [10.1016/j.cemconcomp.2007.09.004](https://doi.org/10.1016/j.cemconcomp.2007.09.004).
- [146] M. Şahmaran, S.B. Keskin, G. Ozerkan, et al., Self-healing of mechanically loaded self consolidating concretes with high volumes of fly ash, *Cem. Concr. Compos.* 30 (10) (2008) 872–879, <https://doi.org/10.1016/j.cemconcomp.2008.07.001>.
- [147] M. Şahmaran, G. Yildirim, T.K. Erdem, Self-healing capability of cementitious composites incorporating different supplementary cementitious materials, *Cem. Concr. Compos.* 35 (2013) 89–101, <https://doi.org/10.1016/j.cemconcomp.2012.08.013>.
- [148] M. Şahmaran, G. Yildirim, E. Ozbay, K. Ahmed, M. Lachemi, Self-healing ability of cementitious composites: effect of addition of pre-soaked expanded perlite, *Mag. Concr. Res.* 66 (8) (2014) 409–419, <https://doi.org/10.1680/mac.13.00250>.
- [149] M. Şahmaran, G. Yildirim, R. Noori, E. Ozbay, M. Lachemi, Repeatability and pervasiveness of Self-Healing in Engineered Cementitious Composites, *ACI Mater. J.* 112 (4) (2015) 513–522, <https://doi.org/10.14359/51687308>.
- [150] M. Sánchez, M.C. Alonso, R. González, Preliminary attempt of hardened mortar sealing by colloidal nanosilica migration, *Constr. Build. Mater.* 66 (2014) 306–312, <https://doi.org/10.1016/j.conbuildmat.2014.05.040>.
- [151] S. Sangadji, V. Wiktor, H. Jonkers, E. Schlangen, The use of alkaliphilic bacteria-based repair solution for porous network concrete healing mechanism, *Procedia Eng.* 171 (2017) 606–613, <https://doi.org/10.1016/j.proeng.2017.01.387>.
- [152] M.A.A. Sherir, K.M.A. Hossain, M. Lachemi, Self-healing and expansion characteristics of cementitious composites with high volume fly ash and MgO-type expansive agent, *Constr. Build. Mater.* 127 (2016) 80–92, <https://doi.org/10.1016/j.conbuildmat.2016.09.125>.
- [153] H. Siad, A. Alyousif, O. Kasap Keskin, S. Bahadır Keskin, M. Lachemi, M. Şahmaran, K.M. Anwar Hossain, Influence of limestone powder on mechanical, physical and self-healing behavior of Engineered Cementitious Composites, *Constr. Build. Mater.* 99 (2015) 1–10, <https://doi.org/10.1016/j.conbuildmat.2015.09.007>.
- [154] K. Sisomphon, O. Copuroglu, (2011). Self healing mortars by using different cementitious materials. Proceedings International RILEM Conference on Advances in Construction Materials through Science and Engineering, Hong Kong, China, 27–29 June 2011, Leung, C. and Wan, K.T., eds., RILEM Publications SARL.
- [155] K. Sisomphon, O. Copuroglu, E.A.B. Koenders, Self-healing of surface cracks in mortars with expansive additive and crystalline additive, *Cem. Concr. Compos.* 34 (2012) 566–574, <https://doi.org/10.1016/j.cemconcomp.2012.01.005>.
- [156] D. Snoeck, N. De Belie, Mechanical and self-healing properties of cementitious composites reinforced with flax and cottonised flax, and compared with polyvinyl alcohol fibres, *Biosyst. Eng.* 111 (2012) 325–334, <https://doi.org/10.1016/j.biosystemseng.2011.12.005>.
- [157] D. Snoeck, S. Steuperaert, K. Van Tittelboom, P. Dubruel, N. De Belie, Visualization of water penetration in cementitious materials with superabsorbent polymers by means of neutron radiography, *Cem. Concr. Res.* 42 (8) (2012) 1113–1121, <https://doi.org/10.1016/j.cemconres.2012.05.005>.
- [158] D. Snoeck, K. Van Tittelboom, S. Steuperaert, P. Dubruel, N. De Belie, Self-healing cementitious materials by the combination of microfibers and superabsorbent polymers, *J. Intell. Mater. Syst. Struct.* 25 (1) (2014) 13–24, <https://doi.org/10.1177/1045389X12438623>.
- [159] D. Snoeck, N. De Belie, From straw in bricks to modern use of microfibers in cementitious composites for improved autogenous healing, A review. *Construction and Building Materials* 95 (2015) 774–787, <https://doi.org/10.1016/j.conbuildmat.2015.07.18>.
- [160] D. Snoeck, P. Smetryns, N. De Belie, Improved multiple cracking and autogenous healing in cementitious materials by means of chemically-treated natural fibres, *Biosyst. Eng.* 139 (2015) 87–99, <https://doi.org/10.1016/j.biosystemseng.2015.08.007>.
- [161] D. Snoeck, N. De Belie, Repeated autogenous healing in strain-hardening cementitious composites by using superabsorbent polymers, *ASCE J. Mater. Civil Eng.* 28 (1) (2016) 1–11, [https://doi.org/10.1061/\(ASCE\)MT.1943-5533.0001360](https://doi.org/10.1061/(ASCE)MT.1943-5533.0001360).
- [162] D. Snoeck, J. Dewanckele, V. Cnudde, N. De Belie, X-ray computed microtomography to study autogenous healing of cementitious materials promoted by superabsorbent polymers, *Cem. Concr. Compos.* 65 (2016) 83–93, <https://doi.org/10.1016/j.cemconcomp.2015.10.016>.
- [163] Y.-K. Song, Y.-H. Jo, Y.-J. Lim, S.-Y. Cho, H.-C. Yu, S.-I. Ryu, C.-M. Chung, Sunlight-induced self-healing of a microcapsule-type protective coating, *ACS Appl. Mater. Interfaces* 5 (4) (2013) 1378–1384, <https://doi.org/10.1021/am302728m>.
- [164] G. Souradeep, H.W. Kua, Encapsulation Technology and Techniques in Self-Healing Concrete, *ASCE Journal of Materials in Civil Engineering* 28 (12) (2016) 1–15, [https://doi.org/10.1061/\(ASCE\)JMT.1943-5533.0001687](https://doi.org/10.1061/(ASCE)JMT.1943-5533.0001687).
- [165] C. Stuckrath, R. Serpell, L.M. Valenzuela, M. Lopez, Quantification of chemical and biological calcium carbonate precipitation: Performance of self-healing in reinforced mortar containing chemical admixtures, *Cem. Concr. Compos.* 50 (2014) 10–15, <https://doi.org/10.1016/j.cemconcomp.2014.02.005>.
- [166] O. Teall, R. Davies, M. Pilegis, A. Kanellopoulos, T. Sharma, K. Paine, A. Jefferson, R. Lark, D. Gardner, A. Al-Tabaa, 2016 Self healing concrete full scale site trials. In: Proceedings of the 11th fib International PhD Symposium in Civil Engineering, 639–646.
- [167] O. Teall, R. Davies, M. Pilegis, A. Kanellopoulos, T. Sharma, D. Gardner, K. Paine, A. Jefferson, A. Abir Al-Tabaa, R. Lark, Large Scale Application of Self-Healing Concrete: Design, Construction and Testing, Case Studies in Construction Materials, 2017 (Submitted for publication).
- [168] E. Teomete, Measurement of crack length sensitivity and strain gage factor of carbon fiber reinforced cement matrix composites, *Measurement* 74 (2015) 21–30, <https://doi.org/10.1016/j.measurement.2015.07.021>.
- [169] P. Termkhajornkit, T. Nawa, Y. Yamashiro, et al., Self-healing ability of fly ash-cement systems, *Cem. Concr. Compos.* 31 (2009) 195–203, <https://doi.org/10.1016/j.cemconcomp.2008.12.009>.
- [170] R.D. Toledo Filho, K. Ghavami, M.A. Sanjuán, G.L. England, Free, restrained and drying shrinkage of cement mortar composites reinforced with vegetable fibres, *Cem. Concr. Compos.* 27 (2005) 537–546, <https://doi.org/10.1016/j.cemconcomp.2004.09.005>.
- [171] J.M. Torrents, T.O. Mason, A. Peled, S.P. Shah, E.J. Garboczi, Analysis of impedance spectra of short conductive fiber reinforced composites, *J. Mater. Sci.* 36 (16) (2001) 4003–4012, <https://doi.org/10.1023/A:1017986608910>.
- [172] E. Tziviloglou, V. Wiktor, J. Wang, K. Paine, M. Alazhari, A. Richardson, M. Guegun, N. De Belie, E. Schlangen, H. Jonkers, (2016). Evaluation of experimental methodology to assess the sealing efficiency of bacteria based self-healing concrete: round robin test. In: Wiktor, V., Jonkers H., Bertron, A. (eds.) Proceedings of the RILEM conference on microorganisms-cementitious materials interactions. RILEM Proceedings PRO102, 23 June 2016, Delft, p 43 in book of abstracts and 15 p. paper online. E-ISBN: 978-2-35158-160-5.
- [173] S. Vaidya, E.N. Allouche, Strain sensing of carbon fiber reinforced geopolymer concrete, *Mater. Struct.* 44 (2011) 1467–1475, <https://doi.org/10.1617/s11527-011-9711-3>.
- [174] B. Van Belleghem, J. Dewanckele, V. Cnudde, N. De Belie, (2015). Analysis and visualization of water uptake in cracked and healed mortar by water absorption tests and X-ray radiography. In: Dehn F. et al., (eds.), Proceedings of the 4th International Conference on Concrete Repair, Rehabilitation and Retrofitting (ICCRRR), Leipzig, Germany, 5–7 October 2015. CRC Press, Boca Raton, p. 45–53. ISBN 978-1-138-02843-2.
- [175] B. Van Belleghem, R. Montoya, J. Dewanckele, N. Van den Steen, I. De Graeve, J. Deconinck, V. Cnudde, K. Van Tittelboom, N. De Belie, Capillary water absorption in cracked and uncracked mortar—A comparison between experimental study and finite element analysis, *Constr. Build. Mater.* 110 (2016) 154–162, <https://doi.org/10.1016/j.conbuildmat.2016.02.027>.
- [176] P. Van den Heede, B. Van Belleghem, N.M. Alderete, K. Van Tittelboom, N. De Belie, Neutron radiography based visualization and profiling of water uptake in (un)cracked and autonomously healed cementitious materials, *Materials* 9 (5) (2016), <https://doi.org/10.3390/ma9050311>.
- [177] K. Van Tittelboom, N. De Belie, W. De Muynck, W. Verstraete, Use of bacteria to repair cracks in concrete, *Cem. Concr. Res.* 40 (2010) 157–166, <https://doi.org/10.1016/j.cemconres.2009.08.025>.
- [178] K. Van Tittelboom, K. Adesanya, P. Dubruel, et al., Methyl methacrylate as a healing agent for self-healing cementitious materials, *Smart Mater. Struct.* 20 (2011) 125016, <https://doi.org/10.1088/0964-1726/20/12/125016>.
- [179] K. Van Tittelboom, N. De Belie, D. Van Loo, P. Jacobs, Self-healing efficiency of cementitious materials containing tubular capsules filled with healing agent, *Cem. Concr. Compos.* 33 (2011) 497–505, <https://doi.org/10.1016/j.cemconcomp.2011.01.004>.
- [180] K. Van Tittelboom, E. Gruyaert, H. Rahier, N. De Belie, Influence of mix composition on the extent of autogenous crack healing by continued hydration or calcium carbonate formation 349 349, *Constr. Build. Mater.* 37 (2012), <https://doi.org/10.1016/j.conbuildmat.2012.07.026>.
- [181] K. Van Tittelboom, N. De Belie, F. Lehmann, C. Grosse, Acoustic emission analysis for the quantification of autonomous crack healing in concrete,

- Constr. Build. Mater. 28 (2012) 333–341, <https://doi.org/10.1016/j.conbuildmat.2011.08.079>.
- [182] K. Van Tittelboom, N. De Belie, Self-healing in cementitious materials – a review, *Materials* 6 (2013) 2182–2217, <https://doi.org/10.3390/ma6062182>.
- [183] K. Van Tittelboom, D. Snoeck, P. Vontobel, F.H. Wittmann, N. De Belie, Use of neutron radiography and tomography to visualize the autonomous crack sealing efficiency in cementitious materials, *Mater. Struct.* 46 (2013) 105–121. [10.1016/j.matsuc.2012.11.009](https://doi.org/10.1016/j.matsuc.2012.11.009).
- [184] K. Van Tittelboom, J. Wang, M. Araujo, D. Snoeck, E. Gruyaert, B. Debbaut, H. Derluyn, V. Cnudde, E. Tsangouri, D. Van Hemelrijk, N. De Belie, Comparison of different approaches for self-healing concrete in large-scale lab tests, *Constr. Build. Mater.* 107 (2016) 125–137. [10.1016/j.conbuildmat.2015.12.186](https://doi.org/10.1016/j.conbuildmat.2015.12.186).
- [185] Y.A. Villagrán Zaccardi, N.M. Alderete, N. De Belie, Improved model for capillary absorption in cementitious materials: Progress over the fourth root of time, *Cem. Concr. Res.* 100 (2017) 153–165. [10.1016/j.cemconres.2017.07.003](https://doi.org/10.1016/j.cemconres.2017.07.003).
- [186] K.T. Wan, C.K.Y. Leung, Applications of a distributed fiber optic crack sensor for concrete structures, *Sens. Actuators, A* 135 (2) (2007) 458–464, <https://doi.org/10.1016/j.sna.2006.09.004>.
- [187] K. Wang, D.C. Jansen, S.P. Shah, et al., Permeability study of cracked concrete, *Cem. Concr. Res.* 27 (3) (1997) 381–393, [https://doi.org/10.1016/S0008-8846\(97\)00031-8](https://doi.org/10.1016/S0008-8846(97)00031-8).
- [188] J. Wang, K. Van Tittelboom, N. De Belie, W. Verstraete, Use of silica gel or polyurethane immobilized bacteria for self-healing concrete, *Constr. Build. Mater.* 26 (2012) 532–540. [10.1016/j.conbuildmat.2011.06.054](https://doi.org/10.1016/j.conbuildmat.2011.06.054).
- [189] J. Wang, N. De Belie, W. Verstraete, Diatomaceous earth as a protective vehicle for bacteria applied for self-healing concrete, *J. Ind. Microbiol. and Biotechnology* 39 (4) (2012) 567–577, <https://doi.org/10.1007/s10295-011-1037-1>.
- [190] X. Wang, F. Xing, M. Zhang, et al., Experimental Study on Cementitious Composites Embedded with Organic Microcapsules, *Materials* 6 (2013) 4064–4081, <https://doi.org/10.3390/ma6094064>.
- [191] J.Y. Wang, D. Snoeck, S. Van Blierberghe, W. Verstraete, N. De Belie, Application of hydrogel encapsulated carbonate precipitating bacteria for approaching a realistic self-healing in concrete, *Constr. Build. Mater.* 68 (2014) 110–119, <https://doi.org/10.1016/j.conbuildmat.2014.06.018>.
- [192] J. Wang, J. Dewanckele, V. Cnudde, S. Van Vlierberghe, W. Verstraete, N. De Belie, X-ray computed tomography proof of bacterial-based self-healing in concrete, *Cem. Concr. Compos.* 53 (2014) 289–304, <https://doi.org/10.1016/j.cemconcomp.2014.07.014>.
- [193] J.Y. Wang, H. Soens, W. Verstraete, N. De Belie, Self-healing concrete by use of microencapsulated bacterial spores, *Cem. Concr. Res.* 56 (2014) 139–152. [10.1016/j.cemconres.2013.11.009](https://doi.org/10.1016/j.cemconres.2013.11.009).
- [194] J. Wang, A. Mignon, D. Snoeck, V. Wiktor, S. Van Vlierberghe, N. Boon, N. De Belie, Application of modified-alginate encapsulated carbonate producing bacteria in concrete: a promising strategy for crack self-healing, *Front. Microbiol.* 6 (2015), <https://doi.org/10.3389/fmicb.2015.01088>.
- [195] X. Wang, P. Sun, N. Han, F. Xing, Experimental study on mechanical properties and porosity of organic microcapsules based self-healing cementitious composite, *Materials* 10 (2017) 20, <https://doi.org/10.3390/ma1001002>.
- [196] X.F. Wang, J.H. Zhang, W. Zhao, R. Han, N.X. Han, F. Xing, Permeability and pore structure of microcapsule-based self-healing cementitious composite, *Constr. Build. Mater.* 165 (2018) 149–162, <https://doi.org/10.1016/j.conbuildmat.2017.12.008>.
- [197] S. Wen, D.D.L. Chung, Piezoresistivity in continuous carbon fiber cement-matrix composite, *Cem. Concr. Res.* 29 (1999) 445–449, [https://doi.org/10.1016/S0008-8846\(98\)00211-7](https://doi.org/10.1016/S0008-8846(98)00211-7).
- [198] S. Wen, D.D.L. Chung, Electrical-resistance-based damage self-sensing in carbon fiber reinforced cement, *Carbon* 45 (710–716) (2007) 2007, <https://doi.org/10.1016/j.carbon.2006.11.029>.
- [199] S. Wen, S. Wang, D.D.L. Chung, Piezoresistivity in continuous carbon fiber polymer-matrix and cement-matrix composites, *J. Mater. Sci.* 35 (2000) 3669–3675, <https://doi.org/10.1023/A:1004842303468>.
- [200] S.L. Williams, N. Sakib, M.J. Kirisits, R.D. Ferron, Flexural strength recovery induced by vegetative bacteria added to mortar, *ACI Mater. J.* 113 (2016) 523–531.
- [201] P.P. Win, M. Watanabe, A. Machida, Penetration profile of chloride ion in cracked reinforced concrete, *Cem. Concr. Res.* 34 (2004) 1073–1079. [10.1016/j.cemconres.2003.11.020](https://doi.org/10.1016/j.cemconres.2003.11.020).
- [202] M. Wu, B. Johannesson, M. Geiker, A review: self-healing in cementitious materials and engineered cementitious composite as a self-healing material, *Constr. Build. Mater.* 28 (2012) 571–583, <https://doi.org/10.1016/j.conbuildmat.2011.08.086>.
- [203] J. Xu, W. Yao, Multiscale mechanical quantification of self-healing concrete incorporating non-ureolytic bacteria-based healing agent, *Cem. Concr. Res.* 64 (2014) 1–10. [10.1016/j.cemconres.2014.06.003](https://doi.org/10.1016/j.cemconres.2014.06.003).
- [204] J. Xu, W. Yao, Z. Jiang, Non-ureolytic bacterial carbonate precipitation as a surface treatment strategy on cementitious materials, *ASCE Journal of Materials in Civil Engineering* 26 (5) (2014) 983–991, [https://doi.org/10.1061/\(ASCE\)MT.1943-5533.0000906](https://doi.org/10.1061/(ASCE)MT.1943-5533.0000906).
- [205] Y. Yang, M. Lepech, E. Yang, V. Li, Autogenous healing of engineered cementitious composites under wet-dry cycles, *Cem. Concr. Res.* 39 (2009) 382–390. [10.1016/j.cemconres.2009.01.013](https://doi.org/10.1016/j.cemconres.2009.01.013).
- [206] Z. Yang, J. Hollar, X. He, et al., Self-healing cementitious composite using oil core/silica gel shell microcapsules, *Cem. Concr. Compos.* 33 (2011) 506–512, <https://doi.org/10.1016/j.cemconcomp.2011.01.010>.
- [207] Y. Yang, E.-H. Yang, V.C. Li, Autogenous healing of engineered cementitious composites at early age, *Cement Concr. Res.* 41 (2011) 176–183, <https://doi.org/10.1016/j.cemconres.2010.11.002>.
- [208] H. Ye, N. Jin, X. Jin, C. Fu, Model of chloride penetration into cracked concrete subject to drying-wetting cycles, *Constr. Build. Mater.* 36 (2012) 259–269, <https://doi.org/10.1016/j.conbuildmat.2012.05.027>.
- [209] G. Yildirim, Ö. Kasap Keskin, S. Bahadır Keskin, S. Şahmaran, M. Lachemi, A review of intrinsic self-healing capability of engineered cementitious composites: recovery of transport and mechanical properties, *Constr. Build. Mater.* 101 (2015) 10–21, <https://doi.org/10.1016/j.conbuildmat.2015.10.018>.
- [210] G. Yildirim, A. Alyousif, M. Şahmaran, M. Lachemi, Assessing the self-healing capability of cementitious composites under increasing sustained loading, *Adv. Cem. Res.* 27 (10) (2015) 581–592, <https://doi.org/10.1680/adcr.14.00111>.
- [211] G. Yildirim, M. Şahmaran, H.U. Ahmed, Influence of Hydrated Lime Addition on the Self-Healing Capability of High-Volume Fly Ash Incorporated Cementitious Composites, *ASCE Journal of Materials in Civil Engineering* 27 (6) (2015) 1–11, [https://doi.org/10.1061/\(ASCE\)MT.1943-5533.0001145](https://doi.org/10.1061/(ASCE)MT.1943-5533.0001145).
- [212] G. Yildirim, G. Hasiloglu Aras, Q.S. Banyhussan, M. Şahmaran, M. Lachemi, Estimating the self-healing capability of cementitious composites through non-destructive electrical-based monitoring, *NDT and E Int.* 76 (2015) 26–37, <https://doi.org/10.1016/j.ndteint.2015.08.005>.
- [213] G. Yildirim, M. Şahmaran, M. Balcikanlib, E. Ozbay, M. Lachemi, Influence of cracking and healing on the gas permeability of cementitious composites, *Constr. Build. Mater.* 85 (2015) 217–226, <https://doi.org/10.1016/j.conbuildmat.2015.02.095>.
- [214] G. Yildirim, A. Hamidzadeh Kiavi, S. Yeşilmen, M. Şahmaran, Self-healing performance of aged cementitious composites, *Cement Concr. Compos.* 87 (2018) 172–186, <https://doi.org/10.1016/j.cemconcomp.2018.01.004>.
- [215] M. Zamir, D. Dvorkin, A. Peled, (2014). Fabric cement-based composites with nanoparticles filler, interfacial characteristics, 3rd International RILEM Conference on Strain Hardening Cementitious Composites (SHCC3), Eds, E. Schlangen, M.G. Sierra Beltram, M. Lukovic, and G. Ye, 3–5 November 2014, Dordrecht Nederland, pp. 171–178.
- [216] Z. Zhang, S. Qian, S. Ma, Investigating mechanical properties and self-healing behavior of micro-cracked ECC with different volume of fly ash, *Constr. Build. Mater.* 52 (2014) 17–23, <https://doi.org/10.1016/j.conbuildmat.2013.11.001>.
- [217] A. Darquennes, K. Olivier, F. Benboudjema, R. Gagné, Self-healing at early-age, a way to improve the chloride resistance of blast-furnace slag cementitious materials, *Constr. Build. Mater.* 113 (2016) 1017–1028, <https://doi.org/10.1016/j.conbuildmat.2016.03.087>.
- [218] C. Edvardsen, Water Permeability and Autogenous Healing of Cracks in Concrete, *ACI Mater. J.* 96 (1999) 448–454.
- [219] H.W. Reinhardt, M. Jooss, Permeability and self-healing of cracked concrete as a function of temperature and crack width, *Cem. Concr. Res.* 33 (2003) 981–985.