

# Experimental Analysis of Fin and Tube Heat Exchanger in Heating and Cooling Mode

Artur Rubcov<sup>1</sup>, Sabina Paulauskaitė<sup>2</sup>, Violeta Misevičiūtė<sup>3</sup>

*Department of Building Energetics, Faculty of Environmental Engineering,  
Vilnius Gediminas Technical University, Vilnius, Lithuania*

*E-mails: <sup>1</sup>[artur.rubcov@stud.vgtu.lt](mailto:artur.rubcov@stud.vgtu.lt) (corresponding author); <sup>2</sup>[sabina.paulauskaitė@vgtu.lt](mailto:sabina.paulauskaitė@vgtu.lt);  
<sup>3</sup>[violeta.miseviciute@vgtu.lt](mailto:violeta.miseviciute@vgtu.lt)*

**Abstract.** The paper provides the results of experimental tests of a wavy fin and tube heat exchanger used to heat (cool) air in a ventilation system when the wavy fin of the heat exchanger is dry and wet. The experimental tests, performed in the range of  $1000 < Re < 4500$  of the Reynolds number, determined the dependency of the heat transfer coefficient on the amount of supplied air with the varying geometry of the heat exchanger (the number of tube rows, the distance between fins, the thickness of the fin and the diameter of the tube). The experimental tests were performed on 9 heat exchangers in heating mode (dry fin) and 6 heat exchangers in cooling mode (wet fin). The ratio of heat transfer coefficient values when the fin is dry and wet varies from 0.79 to 1.12. After processing the results of the experimental tests, equations defining the dependency of the heat transfer coefficient on the amount of air and varying geometric parameters of the heat exchanger were derived, based on which 86% to 88% of the results do not exceed the 10% tolerance margin and the standard deviation varies from 3.5% to 4.3%.

**Keywords:** Air-to-water heat exchanger, wavy fin, dry surface of the fin, wet surface of the fin, heat transfer coefficient.

**Conference topic:** Sustainable building services: energy saving and heat retention, HVAC systems, integrated HVAC design.

## Introduction

As the requirements for energy usage efficiency (STR 2.01.02:2016) in new buildings become tighter, designing mechanical ventilation systems that ensure proper air ventilation and air quality becomes compulsory. When designing such systems, ventilation devices in which air processing operations take place are provided for. Despite heat recovery unit being installed in ventilation devices, in order to retrieve the heat (coolness) of the exhausted air, a part of the heat or coolness has to be given to the supplied air. To achieve this, fin and tube heat exchangers that prepare the air to meet the necessary parameters are typically used.

Currently there is a large variety of configurations of this type of heat exchangers available on the market. When choosing a heat exchanger, it is essential to select it in a size that would ensure not only the parameters of the supplied air under design conditions, but that would also be not too big, because increased pressure losses also increase investment and operational costs.

As the review of previous studies shows (Pirompugd *et al.* 2009; Kim, N. H., Kim, T. 2015), the resistances of the boundary layers of air and water, the tube walls and the fin affect heat transfer the most. Other resistances affect the general resistance only slightly and thus are not analysed. Although there have been many studies completed (Lin *et al.* 2002; Kim 2007; Pirompugd *et al.* 2010; Wang, Liaw 2012) that determine the dependence of the heat transfer coefficient of the boundary layer of air on the Reynolds number, the configuration of each heat exchanger varies (in terms of vertical and horizontal distance between the tubes, the shape of the fin, the diameter of tubes, etc.), the most commonly investigations with the flat-shaped fin have been performed. The experimental results of heat exchanger which consist of such shape fins can be simply comparable with the theoretical data. The dependence of heat transfer coefficient on Reynolds number of heat exchanger produced of wavy shape fins have been chosen to analyse due to lack of investigations those examine characteristics of such shape fins.

After analysing the methodologies used to determine heat transfer coefficient (Taylor 2004; Pirompugd *et al.* 2006; Kastl 2012), the optimal AHRI methodology described in the standard (AHRI 2001) was selected. This methodology is based on logarithmic mean temperature difference (LMTD) (Lin *et al.* 2002) in heating mode and the logarithmic mean enthalpy difference (LMED) (Xia *et al.* 2009) when the cooling mode is analysed (i.e. when the fin of the heat exchanger is completely wet).

The purpose of this paper is to determine the dependency of heat transfer coefficient of the boundary layer of air in Komfovent heat exchangers on the Reynolds number in heating and cooling modes based on the AHRI heat transfer coefficient calculation methodology.

### The description and the calculation methodology of the experiment

The purpose of experimental tests is to determine the dependencies of heat transfer coefficient on the following parameters:

- the distance between fins;
- the thickness of the fin;
- the diameter of the tube;
- the number of tube rows.

In order to achieve this, heat exchangers that had only one varying parameter compared to the base heat exchanger (No. 2) were tested. Table 1 lists the parameters of all heat exchangers:

Table 1. Geometric parameters of heat exchangers

No.	$L_f$ , mm	$L_t$ , mm	$L_c$ , mm	s, mm	N	$D_o$ , mm
1	25.98	30.0	2.4	0.1	2	9.93
2	25.98	30.0	2.4	0.1	4	9.93
3	25.98	30.0	2.4	0.1	6	9.93
4	25.98	30.0	1.6	0.1	4	9.93
5	25.98	30.0	2.0	0.1	4	9.93
6	25.98	30.0	3.0	0.15	4	9.93
7	25.98	30.0	3.6	0.15	4	9.93
8	25.98	30.0	4.0	0.15	4	9.93
9	25.98	30.0	2.4	0.1	4	12.53

Heat exchanger No. 2 was selected as the reference heat exchanger (Table 1). Several parameters of heat exchangers No. 6, No. 7 and No. 8 vary because increased distance between fins ( $L_c$ ) increases the thickness of the fins (Fig. 1). The fins of the tested heat exchangers are wavy. Distinctive parameters and the shape of the fin are shown in Figure 1.

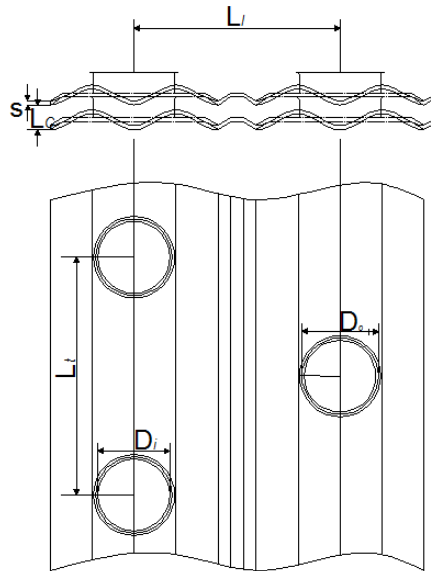

Fig. 1. The shape of the plate of the tested heat exchangers

The tests were carried out in the special heat exchanger testing stand. Its schematic diagram is provided in Figure 2. The heat exchanger testing stand consists of: air flow measurement equipment, air parameter measurement equipment in front of and behind the heat exchanger and water flow and temperature measurement equipment.

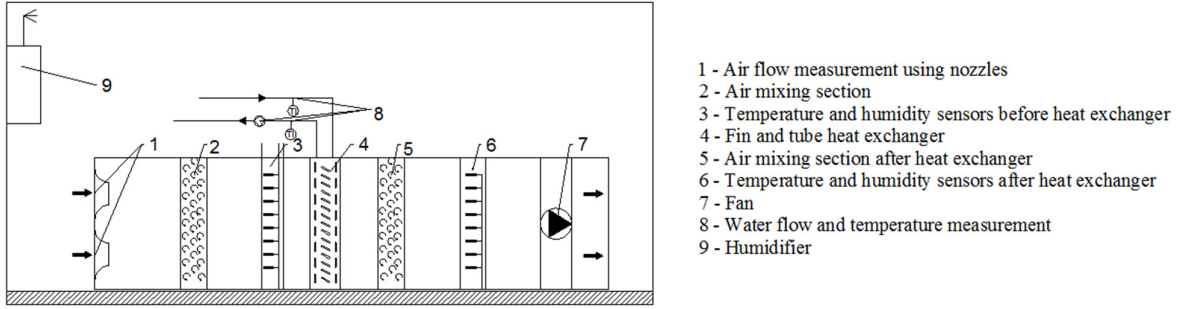

Fig. 2. Schematic diagram of a heat exchanger testing stand

Over the course of experimental tests, heat exchangers are tested by changing the air flow going through it, thus adjusting the dependency of heat transfer on the air flow. The speed of air going through the fin and tube heat exchanger varies from 1 m/s to 5 m/s.

In order to determine the dependency of the heat transfer coefficient on the Reynolds number in the boundary layer of air, we have to find the power of the heat exchanger under certain conditions. The power of the heat exchanger is calculated in two ways (based on air and water parameters) Eq. (1–2) and the arithmetic mean is derived from these results (3):

$$q_{air} = \dot{m}_{air} c_{p,air} \Delta T_{air}, \quad (1)$$

$$q_{wat} = \dot{m}_{wat} c_{p,wat} \Delta T_{wat}, \quad (2)$$

$$q = \frac{q_{air} + q_{wat}}{2}, \quad (3)$$

where:  $q_{air}$ ,  $q_{wat}$ ,  $q$  – heat transfer capacity of air, water and overall, respectively, W;  $\dot{m}_{air}$ ,  $\dot{m}_{wat}$  – mass flow rate of air and water, respectively, kg/s;  $c_{p,air}$ ,  $c_{p,wat}$  – specific heat of air and water, respectively, kJ/kg °C;  $\Delta T_{air}$ ,  $\Delta T_{wat}$  – temperature difference, °C, K.

Having determined the power of the heat exchanger (3), we can calculate the overall heat transfer coefficient (4–5). The LMTD method (4) is used for the heating mode and the LMED method (5) is used for the cooling mode.

$$q = \frac{A \Delta T_m}{R}, \quad (4)$$

$$q = \frac{A \Delta h_m}{c_{p,a} R_{a,W}}, \quad (5)$$

where:  $A$  – area, m<sup>2</sup>;  $\Delta T_m$ ,  $\Delta h_m$  – logarithmic mean of temperature (°C) and enthalpy (kJ/kg), respectively;  $\Delta T_{air}$ ,  $\Delta T_{wat}$  – temperature difference, °C, K;  $R$  – thermal resistance, referred to total external area, m<sup>2</sup>·°C/W;  $R_{a,W}$  – thermal resistance of wet surface in air side, referred to total external area, m<sup>2</sup>·°C/W.

Following the LMTD method, in the Eq. (6) air and water temperature differences are used while following the LMED method, differences of air and fin external surface enthalpies are used (7). Eqs (6) and (7) are used for the cross flow heat exchangers.

$$\Delta T_m = \frac{(t_{w1} - t_{a2}) - (t_{w2} - t_{a1})}{\ln \frac{(t_{w1} - t_{a2})}{(t_{w2} - t_{a1})}}, \quad (6)$$

$$\Delta h_m = \frac{(h_{a1} - h_{s2}) - (h_{a2} - h_{s1})}{\ln \frac{(h_{a1} - h_{s2})}{(h_{a2} - h_{s1})}}, \quad (7)$$

where:  $t_{w1}$ ,  $t_{w2}$  – temperature of entering (leaving) coil water respectively, °C;  $t_{a1}$ ,  $t_{a2}$  – temperature of entering (leaving) coil air, respectively, °C;  $h_{a1}$ ,  $h_{a2}$  – enthalpy of entering (leaving) air, respectively, kJ/kg;  $h_{s1}$ ,  $h_{s2}$  – enthalpy of entering (leaving) saturated air at coil surface, respectively, kJ/kg.

In Equation (4), total resistance of the heat exchanger ( $R$ ) is used which consists of resistances of boundary layers of water and air as well as thermal resistances of the tube and the fin (8):

$$R = R_w + R_t + R_f + R_{aD}, \quad (8)$$

where:  $R_w, R_{aD}$  – thermal resistance of water and dry air side boundary layer, respectively,  $\text{m}^2 \cdot \text{°C}/\text{W}$ ;  $R_t, R_f$  – thermal resistance of tube and fin, respectively,  $\text{m}^2 \cdot \text{°C}/\text{W}$ .

The resistance coefficient ( $R_w$ ) of the boundary layer of water is determined by using the Pethukov-Kirillov method (9) (Taler 2016):

$$R_w = \frac{B}{h_w}, \quad (9)$$

$$h_w = \frac{Nu_w k_w}{D_i}, \quad (10)$$

$$Nu_w = \frac{\frac{f}{8} (Re_w - 1000) Pr_w}{1 + 12.7 \left(\frac{f}{8}\right)^{1/2} (Pr^{2/3} - 1)} \left(1 + \frac{D_i}{L}\right)^{2/3}, \quad (11)$$

$$f = (1.8 \log(Re_w) - 1.5)^{-2}, \quad (12)$$

where:  $B$  – ratio of total external coil surface area to the total internal surface area;  $h_w$  – water side convection heat transfer coefficient,  $\text{W}/(\text{m}^2 \cdot \text{°C})$ ;  $Nu$  – Nusselt number;  $k_w$  – material thermal conductivity,  $\text{W} \cdot \text{mm}/(\text{m}^2 \cdot \text{°C})$ ;  $D_i$  – inner diameter of the tube,  $\text{m}$ ;  $f$  – friction factor,  $\text{W}/(\text{m}^2 \cdot \text{°C})$ ;  $Re_w$  – Reynolds number;  $Pr_w$  – Prandtl number;  $L$  – length,  $\text{m}$ .

The thermal resistance of the boundary layer of air ( $R_{aD}$ ) is calculated on the basis of the Eq. (13):

$$R_{aD} = \frac{1}{h_{aD}}, \quad (13)$$

where:  $h_{aD}$  – air side convection heat transfer coefficient,  $\text{W}/(\text{m}^2 \cdot \text{°C})$ .

The thermal resistance of the tube ( $R_t$ ) is calculated on the basis of the Eq. (14):

$$R_t = \frac{BD_i}{2k_t} \ln \frac{D_o}{D_i}, \quad (14)$$

where:  $D_o$  – tube outside diameter,  $\text{m}$ ;  $k_t$  – thermal conductivity of the tube,  $\text{W}/(\text{m} \cdot \text{°C})$ .

The thermal resistance of the fin ( $R_f$ ) is calculated on the basis of the Eq. (15) using the values calculated based on Eqs (16–21):

$$R_f = \left(\frac{1-\eta}{\eta}\right) R_{aD}, \quad (15)$$

$$\eta = \frac{\eta_{fin} A_{sec} + A_{prim}}{A_0}, \quad (16)$$

$$\eta_{fin} = \frac{\tanh(mr_t \phi)}{mr_t \phi}, \quad (17)$$

where:  $\eta$  – total external surface effectiveness;  $\eta_{fin}$  – fin efficiency;  $A_{sec}$  – secondary surface area,  $\text{m}^2$ ;  $A_{prim}$  – primary surface area,  $\text{m}^2$ ;  $A_0$  – total external surface area,  $\text{m}^2$ ;  $r_t$  – radius of the tube,  $\text{m}$ ;  $m$  and  $\phi$  – fin characteristics

$$m = \sqrt{\frac{2\alpha_{aD}}{k_a s}}, \quad (18)$$

$$\phi = \left(\frac{r_e}{r_b} - 1\right) \left(1 + 0.35 \ln \left(\frac{r_e}{r_b}\right)\right), \quad (19)$$

$$r_e = 1.27 \frac{L_t}{2} 0.7^{0.5}, \quad (20)$$

$$r_b = \frac{D_0 + 2s}{2}, \quad (21)$$

where:  $k_a$  – air thermal conductivity,  $W \cdot mm / (m^2 \cdot ^\circ C)$ ;  $s$  – the thickness of the fin,  $m$ ;  $r_e, r_b$  – equivalent and external collar radius, respectively,  $m$ ;  $L_l$  – length of the tube,  $m$ .

By using Eqs (8–16) the thermal resistance of the boundary layer of air  $R_{aD}$  is determined using the iteration method.

When heat transfer in cooling mode is analysed, the thermal resistance of the boundary layer of air ( $R_{aW}$ ) is determined by using the Eq. (22):

$$R_{aW} = K_w R_{aD}, \quad (22)$$

The  $K_w$  coefficient, required to assess the thermal resistance of the boundary layer of air is derived from experimental tests.

## Results

After performing the tests, the dependencies of the heat transfer coefficient on the varying parameters of the heat exchanger were determined. These dependencies are shown in Figures 3 to 5. Figure 3 shows how the heat transfer coefficient of the boundary layer of air changes depending on the Reynolds number and the number of tube rows.

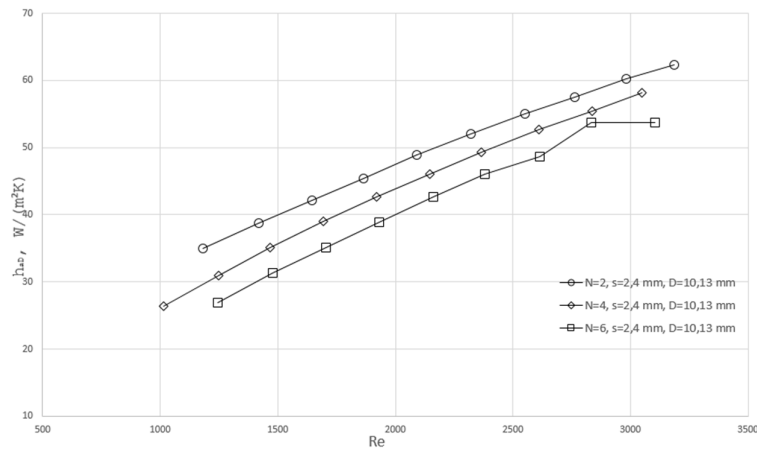

Fig. 3. The dependency of the heat transfer coefficient of the boundary layer of air on the Reynolds number and the number of tube rows

Tests determined that as the number of tube rows increases, the heat transfer coefficient decreases.

Meanwhile, in terms of the dependency of the heat transfer on the distance between fins, the heat transfer coefficient generally increases as the distance between the fins increases, however, there were exceptions when the heat transfer coefficient dropped.

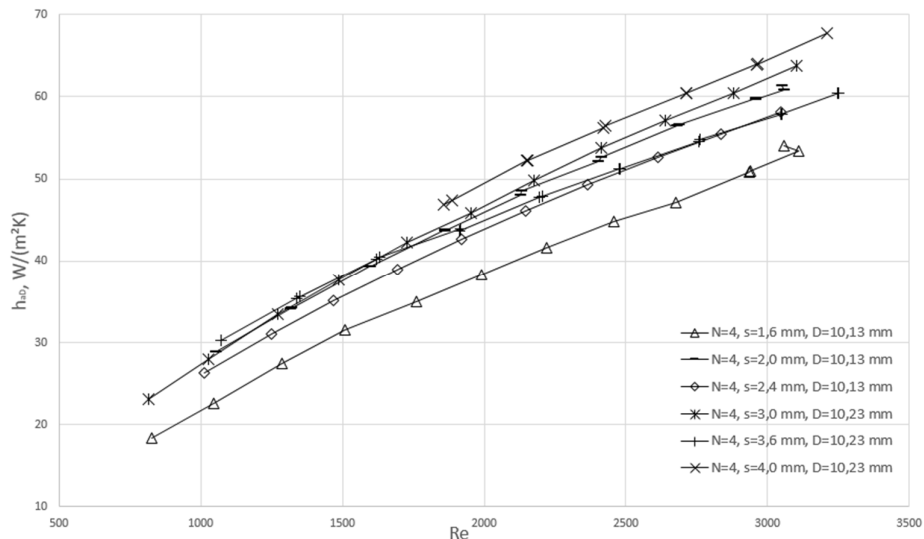

Fig. 4. The dependency of the heat transfer coefficient of the boundary layer of air on the Reynolds number and the distance between fins

When analysing the effect of the diameter of the tube on the heat exchange it was noticed that increasing the diameter of the tube leads to a significant increase of the heat transfer coefficient when the flow remains the same. However, when the dependency on the Reynolds number is analysed, the heat transfer coefficient drops.

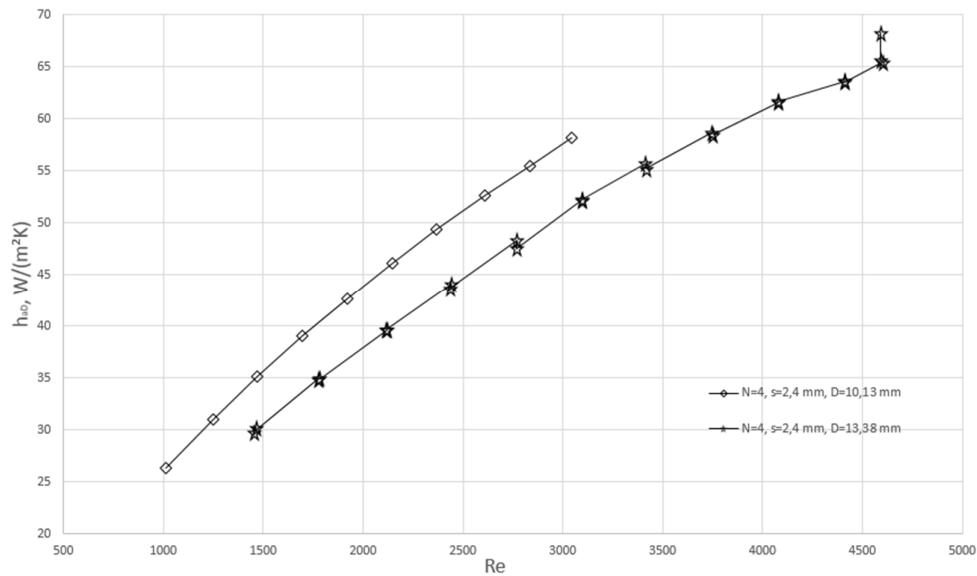

Fig. 5. The dependency of the heat transfer coefficient of the boundary layer of air on the Reynolds number and the diameter of tubes

An empiric Eq. (23) was derived for all analysed heat exchangers, based on which the heat transfer coefficient in the boundary layer depending on the Reynolds number can be determined for each heat exchanger:

$$h_{aD} = 2.577e^{-0.417N} \frac{L_c^{1.288}}{s^{0.795}} D^{-0.5087} (Re-250)^{\frac{1}{0.003811s^{-0.3547} 0.5731L_c^{0.3770} + 0.04947N}} \mu, \quad (23)$$

After performing calculations on the basis of Eq. (23), heat coefficient values derived from experimental tests are compared with calculated values. Figure 6 shows that the majority of values fall into the range of  $\pm 10\%$  (marked with a dashed line). The tolerance margin of only one heat exchanger ( $N = 2$ ,  $L_c = 2.0$  mm,  $D = 10.13$  mm) exceeds the tolerance margin of 10%.

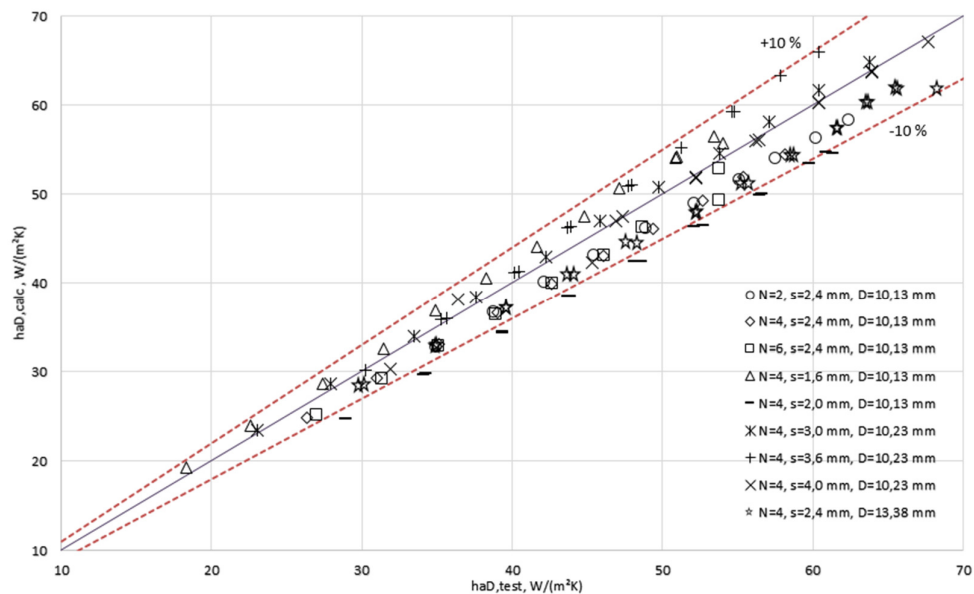

Fig. 6. The comparison of the experimental and calculated heat transfer values

After the dependency of the heat transfer coefficient is determined in the heating mode, experimental tests are performed in the cooling mode in order to determine how the condensate that forms on the surface of plate of the heat exchanger affects the heat exchange. During the experimental test, conditions ensuring that the entire surface of the heat exchanger is wet are created. The results of the experiment are shown in Figure 7.

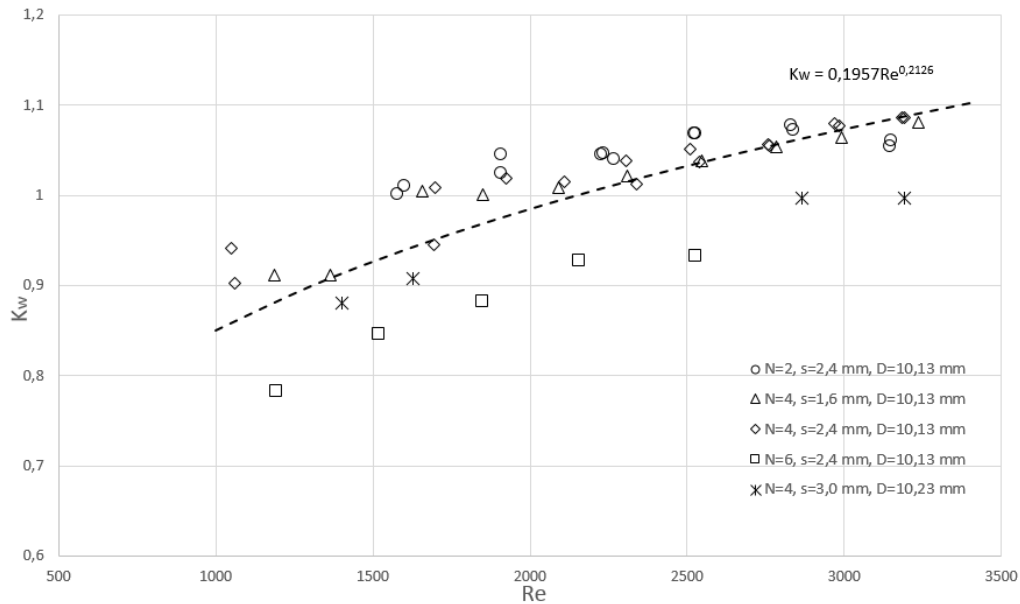

Fig. 7. The dependence of  $K_w$  on the Reynolds number

After the tests the dependence of  $K_w$  on the Reynolds number was determined:

$$K_w = 0.1957Re^{0.2126}, \quad (24)$$

The largest deviation of the formula above the data is 12.49%, meanwhile the deviation of the heat exchanger capacity using this formula in this point 3.70%.

## Conclusions

1. The heat transfer coefficient in the boundary layer of air drops as the number of tube rows in the heat exchanger increases.
2. The heat transfer coefficient in the boundary layer of air goes up as the distance between fins increases.
3. An empiric equation has been derived that describes the heat transfer coefficient of the heat exchanger with the analysed geometry of the plate with the tolerance of  $\pm 10\%$ .
4. In the cooling mode, the thermal resistance coefficient of the boundary layer of air varies in the range from 0.75 to 1.1, depending on the Reynolds number.

## References

- Air-Conditioning Heating and Refrigeration Institute (AHRI)*. 2001. AHRI Standard 410-2001 – 2001 Standard for Forced-Circulation Air Cooling and Air-Heating Coils.
- Kastl, B. K. 2012. *Dehumidifying coil models for energy simulation and desing*. 111 p.
- Kim, B.Y. & N. H. 2007. *An experimental investigation on the airside performance of fin- and-tube heat exchangers having sinusoidal wave fins*, 1249–1262.
- Kim, N. H.; Kim, T. 2015. An experimental investigation on the airside performance of fin-and-tube heat exchangers having slit fins under wet condition, *Journal of Mechanical Science and Technology* 29(11): 5011–5019. <https://doi.org/10.1007/s12206-015-1049-2>
- Lin, Y.; Hwang, Y.; Wang, C. 2002. *Performance of the herringbone wavy fin under dehumidifying conditions* 45: 5035–5044.
- Pirompugd, W.; Wang, C.; Wongwises, S. 2009. A review on reduction method for heat and mass transfer characteristics of fin-and-tube heat exchangers under dehumidifying conditions, *International Journal of Heat and Mass Transfer* 52(9–10): 2370–2378. <https://doi.org/10.1016/j.ijheatmasstransfer.2008.10.019>

- Pirompugd, W.; Wang, C.; Wongwises, S. 2010. Correlations for wet surface ratio of fin-and-tube heat exchangers, *International Journal of Heat and Mass Transfer* 53(1–3): 568–573. <https://doi.org/10.1016/j.ijheatmasstransfer.2009.09.025>
- Pirompugd, W.; Wongwises, S.; Wang, C. C. 2006. Simultaneous heat and mass transfer characteristics for wavy fin-and-tube heat exchangers under dehumidifying conditions, *International Journal of Heat and Mass Transfer* 49(1–2): 132–143. <https://doi.org/10.1016/j.ijheatmasstransfer.2005.05.043>
- STR 2.01.02:2016. 2016. *Pastatų energinio naudingumo projektavimas ir sertifikavimas*.
- Taler, D. 2016. A new heat transfer correlation for transition and turbulent fluid flow in tubes. *International Journal of Thermal Sciences* 108: 108–122. <https://doi.org/10.1016/j.ijthermalsci.2016.04.022>
- Taylor, C. 2004. *Measurement of finned-tube heat exchanger performance measurement of finned-tube heat exchanger*. A Thesis Presented to The Academic Faculty. Georgia Institute of Technology.
- Wang, C.; Liaw, J. 2012. Air-side performance of herringbone wavy fin-and-tube heat exchangers under dehumidifying condition – Data with larger diameter tube, *International Journal of Heat and Mass Transfer* 55(11–12): 3054–3060. <https://doi.org/10.1016/j.ijheatmasstransfer.2012.02.025>
- Xia, L.; Chan, M. Y.; Deng, S. M.; Xu, X. G. 2009. A modified logarithmic mean enthalpy difference (LMED) method for evaluating the total heat transfer rate of a wet cooling coil under both unit and non-unit Lewis Factors, *International Journal of Thermal Sciences* 48(11): 2159–2164.