

Comparison of an Adsorption Refrigeration Unit Operating with Two and Four Adsorbers

Andrzej Grzebielec

Institute of Heat Engineering, Warsaw University of Technology, Warsaw, Poland
E-mail: andrzej.grzebielec@itc.pw.edu.pl

Abstract. Adsorption refrigeration systems can be built with one, two or more adsorbers. The most common devices are built of two adsorbers. This fact makes the achieved cooling capacity is variable over time, and in some periods of operation is even 0 kW. Increased number of adsorbers causes the cooling capacity obtained in time is more balanced. The aim of the study is to compare the most popular operating unit with two adsorbers with the installation which continuously work with four adsorbers. It turns out that such a solution can align cooling capacity during the entire process. This solution does not affect the effectiveness of the device, but only on its size. Adsorbers are the largest part of the device. So this type of solution is dedicated to wherever it is needed fluently providing cooling capacity and there is no possibility of collecting cooling in tanks.

Keywords: refrigeration, adsorption refrigeration, energy efficiency.

Conference topic: Energy for buildings.

Introduction

Adsorption refrigeration systems evolve due to the fact that refrigerants which are environmentally safe substances (Fernández *et al.* 2015). These substances can not be used in conventional vapor compression systems (Kuczyński *et al.* 2013; Rusowicz, Ruciński 2011; Śmierciew *et al.* 2017). The most popular refrigerant are water, methanol and ethanol (Grzebielec *et al.* 2015; Cyklis, Janisz 2015). With the thermoelectric, thermoacoustic, magnetic devices constitute forward-looking branch of the refrigeration and air conditioning (Jaworski *et al.* 2016; Kotowicz *et al.* 2016). For all this reasons adsorption refrigeration is treat as clean (Ruciński *et al.* 2016) and energy safe technology dedicated for building (Grzebielec *et al.* 2014; Jędrzejuk, Dybiński 2015; Jędrzejuk, Rucińska 2015) and industry solutions (Rusowicz *et al.* 2013, 2014).

Due to the fact that in the adsorption refrigeration units, refrigerant passes from the desorber to the absorber in a cyclic manner and with varying intensity, also obtained cooling capacity is variable in time. In systems with a single adsorber cold production process is only 20–30% of the total cycle time. In systems with two adsorbers it looks better, but still there are periods when the cold is generated and periods when it is not generated (Deshmukh *et al.* 2015). For this reason, adsorption units in its first stage of the placing on the market were devices that have been used in such applications where uniformity of production of cold was not required. These were applications related to the ice production, or systems supporting existing air conditioning systems. In the second case, when the adsorption device producing cold, the basic unit has been relieved, which results in an improvement of the total efficiency ratio *EER* of system (Christy, Fusco 2001).

When the adsorption refrigeration unit is the only source of cold and at the same time is required for uniform cooling capacity of the adsorption device must either be fitted with a storage tank, or must be constructed of more adsorbers. This study compares the adsorption device made of two adsorbers to the device built of four absorbers in the condition of uniform cold production.

Construction of adsorption refrigeration devices

Figure 1 shows a device constructed from two adsorption beds. It consists, in addition to said two adsorbers, evaporator, condenser, expansion valve and a series of valves to allow a change of the refrigerant flow between the adsorbers in the right direction (Grzebielec *et al.* 2015; Qu *et al.* 2001; Zhang 2000).

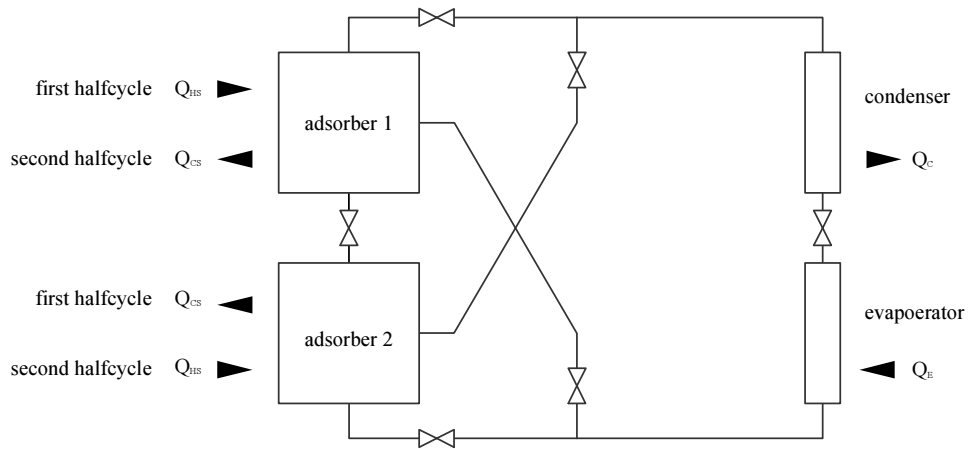

Fig. 1. Two beds adsorption refrigeration unit

Stages of operation cycle have been illustrated in Table 1.

Table 1. Two beds adsorption cycle stages.

	Adsorber 1	Adsorber 2
Stage 1	heating	cooling
Stage 2	desorption	adsorption
Stage 3	cooling	heating
Stage 4	adsorption	desorption

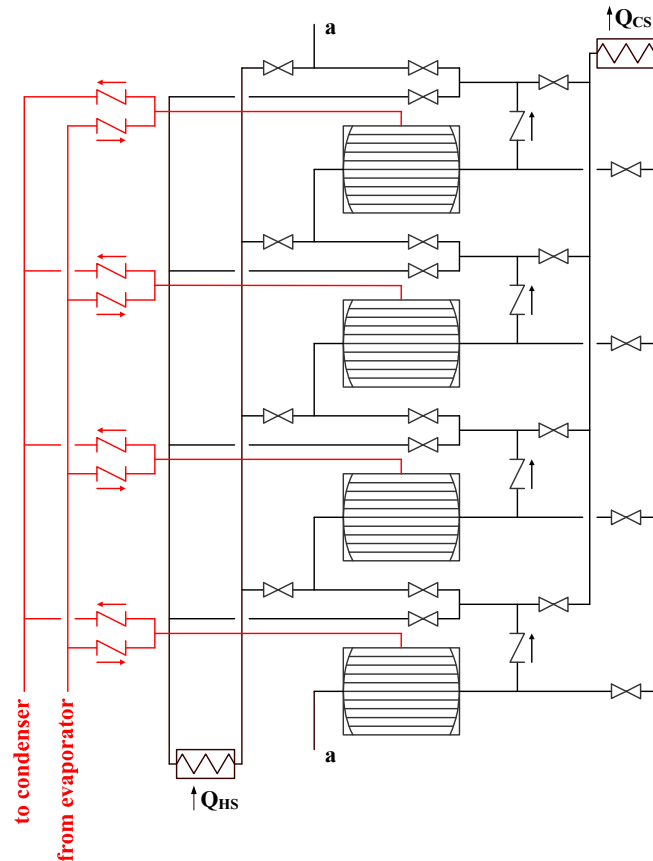

Fig. 2. Adsorption refrigeration unit built of four beds

The construction of the adsorption refrigerating machine built of four beds is presented in Figure 2. It consists of four adsorbers, expansion valve, piping to enable cooling and heating of individual adsorbers. Even more valves, enabling transport refrigerant to the condenser and returning from the evaporator. Adsorbers work is divided into four stages (same as in the case of a device with two adsorbers) but their cooperation is in accordance with the Table 2.

Table 2. Four beds adsorption cycle stages (Christy, Fusco 2001)

	Adsorber 1	Adsorber 2	Adsorber 3	Adsorber 4
Stage 1	heating	adsorption	cooling	desorption
Stage 2	desorption	heating	adsorption	cooling
Stage 3	cooling	desorption	heating	adsorption
Stage 4	adsorption	cooling	desorption	heating

Please note that in the case of adsorption unit with four adsorbers, hot factor derived from the heat source will first flow through the adsorber in which desorption occurs, then it will flow into the adsorber to be warm (Christy, Fusco 2001). A similar situation is in the case of cooling adsorber. First, the secondary fluid will cool the bed in which the adsorption occurs and then will flow into the bed to be cooled. In practice this will mean that in the case of a two beds unit, the heating process is at a higher temperature than in the case of a four beds unit. Lengthen the time the processes of heating and cooling. For the device with four adsorbers is a significant phenomenon since the times of these processes must be equal to the adsorption and desorption times.

Calculation

All adsorbers work by circuit shown in Figure 3. The working pair is activated carbon – methanol. Line A-B is heating process of the adsorber. Line B-C is a desorption process. Line C-D is cooling process of adsorber, and line D-A is adsorption process. In addition, the scheme shows saturation line for methanol to obtain thermophysical properties of methanol in the condenser and evaporator. In research, the condensing temperature T_C is more than 50 °C which means that the process is not dependent on the outdoor temperature. This parameter has a very large impact on both the cooling capacity of the device \dot{Q}_e and on the energy efficiency ratio EER . It is also envisaged very high temperature heat source at 200 °C. It is contemplated that the adsorbers are heated to a temperature of 140 °C. Adsorbers are cooled by a secondary fluid of constant mass flow and constant temperature at the inlet of 20 °C. Adsorbers are in both cases constructed in the form of a bed of 1.5 kg of dry activated carbon. The uptake of methanol varies from $w_{max} = 0.066 \text{ kg/kg}_{AC}$ to $w_{min} = 0.035 \text{ kg/kg}_{AC}$.

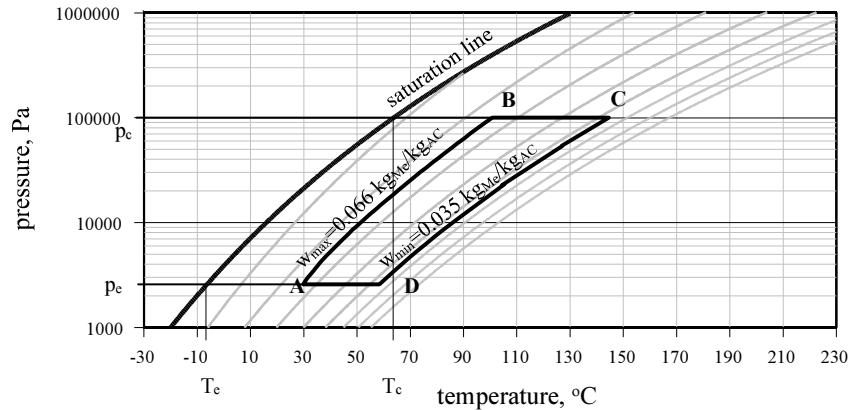

Fig. 3. Thermodynamic states of beds used in research

Methodology

The calculations assume that the beds will have the same temperature, and the heat source will have a constant temperature. What makes the amount of heat required to isosteric conversion can be calculated from Eq. (1):

$$Q_{HS,is} = \int_{T_A}^{T_B} (c_{p,a}(T) + c_{p,CH_3OH}(T) \cdot w_{max}) dT, \quad (1)$$

where: Q – heat (J); t, T – temperature (K); is – isosteric; p – constant pressure; C – condenser; CH_3OH – methanol; w – uptake ($\text{kg}_{ref}/\text{kg}_{ads}$).

and the time required for conversion is determined from the Eq. (2):

$$\frac{\partial T}{\partial \tau} m_{ads} (c_{p,a}(T) + c_{p,CH_3OH}(T) \cdot w_{max}) = k \cdot A \cdot (T_f - T_a), \quad (2)$$

where: m – mass (kg); a, ads – adsorption, adsorbent; k – heat transfer coefficient ($W/(m^2 \cdot K)$); f – secondary fluid. The heat of desorption (line B-C) was calculated according to the Eq. (3):

$$Q_{HS,des} = m_{ads} \int_{w_{max}}^{w_{min}} \Delta H(w) dw \quad (3)$$

where: HS – heat source; des – desorption; ΔH – heat of adsorption (kJ/kg).

where ΔH is the heat of adsorption calculated in accordance with the equations presented in the work Cacciola and Restuccia (Cacciola, Restuccia 1995), $c_{p,a}(T)$ is a specific heat of activated carbon as a function of temperature and $c_{p,CH_3OH}(T)$ is a specific heat of liquid methanol as a function of temperature. In the desorption process there has to be also taken into account that the heat is transferred to the temperature change of dry adsorbent (Eq (4)):

$$Q_{HS,ads} = m_{ads} \cdot \int_{T_B}^{T_C} c_{p,a}(T) dT \quad (4)$$

and the change of temperature of the adsorbed methanol (Eq. (5)):

$$Q_{HS,CH_3OH} = m_{ads} \int_{T_B}^{T_C} c_{p,CH_3OH}(T) \cdot w(T) dT. \quad (5)$$

The time required for the desorption process was also determined from the Eq. (2), wherein the heat supplied to the adsorber is converted to changes in temperature and the heat of desorption.

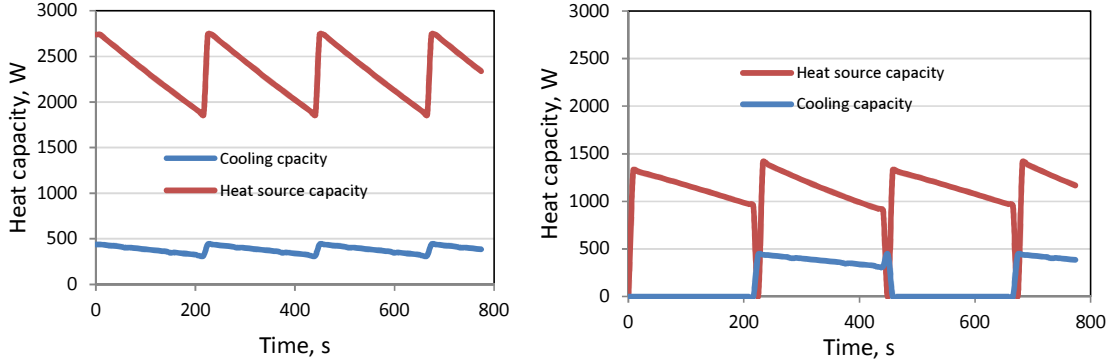

Fig. 4. The change of capacities in time for the devices (4-beds on the left side, 2-beds on the right side)

In Figure 4 there are shown results of calculations for a device consisting of four adsorber (left side) and with a device consisting of two adsorbers (right side). The figure shows that the cooling capacity generated in the four-beds device is more stable than in the case of a two-beds device. For the device built of four adsorbers there was obtained $EER=0.16$, and for two-beds was equal to $EER = 0.15$. Wherein it should be noted that, in the case of a two-beds device it is possible to improve the EER by changing the operating times. In the case of a device built of four adsorbers it can not be change the operating times. Specific cooling power SPC obtained for both solutions are comparable and are 64 W/kg and 57 W/kg respectively for 4- and 2-beds unit.

Conclusions

The calculations have shown that the four-beds units are capable of producing cooling power more evenly across the device than the two-beds unit. Nevertheless, it still is not uniform cooling capacity. The analysis assumes that system will be operating in accordance with the circuit shown in Figure 3. The circuit is based on the assumption that the time for heat delivery to the bed for transition from point A to point B is the same as the transition time from the

point B to the state of point C. Such an approach is required for the four-beds device. In the case of devices built of two adsorbers process times do not have to be equal. And usually these devices operate at different times of these processes – that makes *EER* of systems may be increased. As a result of the research of work of these two devices there was also observed differences in heat source capacities and *EER*. For two-beds devices *EER* is 0.15 and for four-beds it is 0.16. The values of the specific cooling power *SCP* are comparable and are 64 and 57 W/kg, respectively.

The research results also show that the four-beds units requires that parameters of heat source and secondary fluid cooling has to be constant all the time. Otherwise the device will not operate in a stable manner. In the case of two-beds devices these parameters may change – it will only influence on the individual stages time.

Summing up the results of all studies should be stated that the two beds device has more advantages than a four beds devices. Four beds machine will be better in very limited applications.

References

- Cacciola, G.; Restuccia, G. 1995. Reversible adsorption heat pump: A thermodynamic model, *International Journal of Refrigeration* 18: 100–106. [https://doi.org/10.1016/0140-7007\(94\)00005-I](https://doi.org/10.1016/0140-7007(94)00005-I)
- Christy, C.; Fusco, D. 2001. *Toossi R. Adsorption air-conditioning for containerhips and vehicles*. Final Report (California State University Long Beach, METRANS contract number 65A0047, 27 June 2001).
- Cyklis, P.; Janisz, L. 2015. An innovative ecological hybrid refrigeration cycle for high power refrigeration facility, *Chemical and Process Engineering* 36(3): 321–330. <https://doi.org/10.1515/cpe-2015-0022>
- Deshmukh, H.; Maiya, M. P.; Srinivasa Murthy, S. 2015. Continuous vapour adsorption cooling system with three adsorberbeds, *Applied Thermal Engineering* 82: 380–389. <https://doi.org/10.1016/j.applthermaleng.2015.01.013>
- Fernández, A. I.; Sole, A.; Giro-Paloma, J.; Martinez, M.; Hadijeve, M.; et al. 2015. Unconventional experimental technologies used for phase change materials (PCM) characterization. Part 2 – morphological and structural characterization, physico-chemical stability and mechanical properties, *Renewable and Sustainable Energy Reviews* 43: 1415–1426. <https://doi.org/10.1016/j.rser.2014.11.051>
- Grzebielec, A.; Rusowicz, A.; Laskowski, A. 2015. Experimental study on thermal wave type adsorption refrigeration system working on a pair of activated carbon and methanol, *Chemical and Process Engineering* 36(4): 395–404.
- Grzebielec, A.; Rusowicz, A.; Ruciński, A. 2014. Analysis of the performance of the rotary heat exchanger in the real ventilation systems, in *The 9th International Conference “Environmental Engineering”*, 22–23 May 2014, Vilnius, Lithuania.
- Grzebielec, A.; Rusowicz, A.; Ruciński, A. 2015. Use of the methanol-activated carbon sorption set in a refrigeration unit, *Przemysł Chemiczny* 94: 952–955.
- Jaworski, M.; Bednarczyk, M.; Czachor, M. 2016. Experimental investigation of thermoelectric generator (TEG) with PCM module, *Applied Thermal Engineering* 96: 527–533. <https://doi.org/10.1016/j.applthermaleng.2015.12.005>
- Jędrzejuk, H.; Dybiński, O. 2015. The influence of a heating system control program and thermal mass of external walls on the internal comfort in the Polish Climate, *Energy Procedia* 78: 1087–1092. <https://doi.org/10.1016/j.egypro.2015.11.058>
- Jędrzejuk, H.; Rucińska, J. 2015. Verifying a need of artificial cooling - a simplified method dedicated to single-family houses in Poland, *Energy Procedia* 78: 1093–1098. <https://doi.org/10.1016/j.egypro.2015.11.061>
- Kotowicz, J.; Jurczyk, M.; Węcel, D.; Ogulewicz, W. 2016. Analysis of hydrogen production in alkaline electrolyzers, *Journal of Power Technologies* 96 (3): 149–156.
- Kuczyński, W.; Bohdal, T.; Charun, H. 2013. Impact of periodically generated hydrodynamic disturbances on the condensation efficiency of R134a refrigerant in pipe mini-channels, *Experimental Heat Transfer* 26: 64–84. <https://doi.org/10.1080/08916152.2011.642929>
- Qu, T. F.; Wang, R. Z.; Wang, W. 2001. Study on heat and mass recovery in adsorption refrigeration cycles, *Applied Thermal Engineering* 21: 439–452. [https://doi.org/10.1016/S1359-4311\(00\)00050-8](https://doi.org/10.1016/S1359-4311(00)00050-8)
- Ruciński, A.; Rusowicz, A.; Rucińska, K. 2016. Spectral identification of gas and solid wastes from rubber processing, *Przemysł Chemiczny* 95: 1325–1329.
- Rusowicz, A.; Grzebielec, A.; Ruciński, A. 2013. Analysis of the gas turbine selection by the pinch point technology method, *Przemysł Chemiczny* 92: 1476–1479.
- Rusowicz, A.; Grzebielec, A.; Ruciński, A. 2014. Energy conservation in buildings using refrigeration units, in *The 9th International Conference “Environmental Engineering”*, 22–23 May 2014, Vilnius, Lithuania. <https://doi.org/10.3846/enviro.2014.281>
- Rusowicz, A.; Ruciński, A. 2011. The mathematical modelling of the absorption refrigeration machines in energy systems, in *The 8th International Conference Environmental Engineering*, 19–20 May 2011, Vilnius, Lithuania. Selected Papers, 802–806.
- Śmierciew, K.; Gagan, J.; Butrymowicz, D.; Łukaszuk, M.; Kubiczek, H. 2017. Experimental investigation of the first prototype ejector refrigeration system with HFO-1234ze(E), *Applied Thermal Engineering* 110: 115–125. <https://doi.org/10.1016/j.applthermaleng.2016.08.140>
- Zhang, R. Z. 2000. Design and testing of an automobile waste heat adsorption cooling system, *Applied Thermal Engineering* 20: 103–114. [https://doi.org/10.1016/S1359-4311\(99\)00009-5](https://doi.org/10.1016/S1359-4311(99)00009-5)